

eduard



Shachhak 1/48

No. 11128

Limited Edition

ATTENTION



UPOZORNĚNÍ



ACHTUNG



ATTENTION



注意



Carefully read instruction sheet before assembling. When you use glue or paint, do not use near open flame and use in well ventilated room. Keep out of reach of small children. Children must not be allowed to suck any part, or pull vinyl bag over the head.



Před započítím stavby si pečlivě prostudujte stavební návod. Při používání barev a lepidel pracujte v dobře větrané místnosti. Lepidla ani barvy nepoužívejte v blízkosti otevřeného ohně. Model není určen malým dětem, mohlo by dojít k požití drobných dílů.

INSTRUCTION SIGNS

INSTR. SYMBOLS

INSTRUKTION SINNBILDEN

SYMBOLES

記号の説明

OPTIONAL
VOLBABEND
OHNOUTSAND
BROUSITOPEN HOLE
VYVRTAT OTVORSYMETRICAL ASSEMBLY
SYMETRICKÁ MONTÁŽREMOVE
ODŘÍZNOUTREVERSE SIDE
OTOČITAPPLY EDUARD MASK
AND PAINT
POUŽIT EDUARD MASK
NABARVIT

PARTS



DÍLY



TEILE



PIÈCES



部品

PLASTIC PARTS

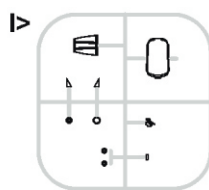
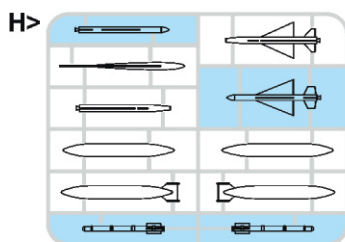
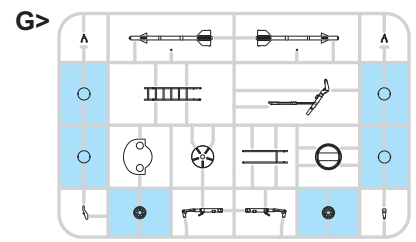
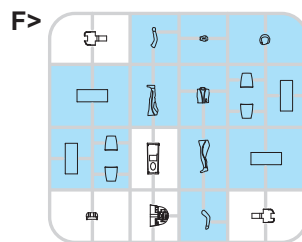
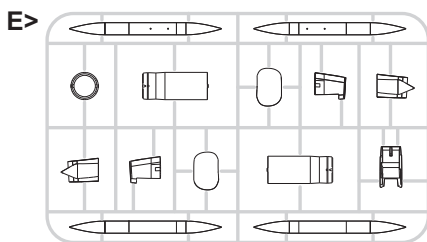
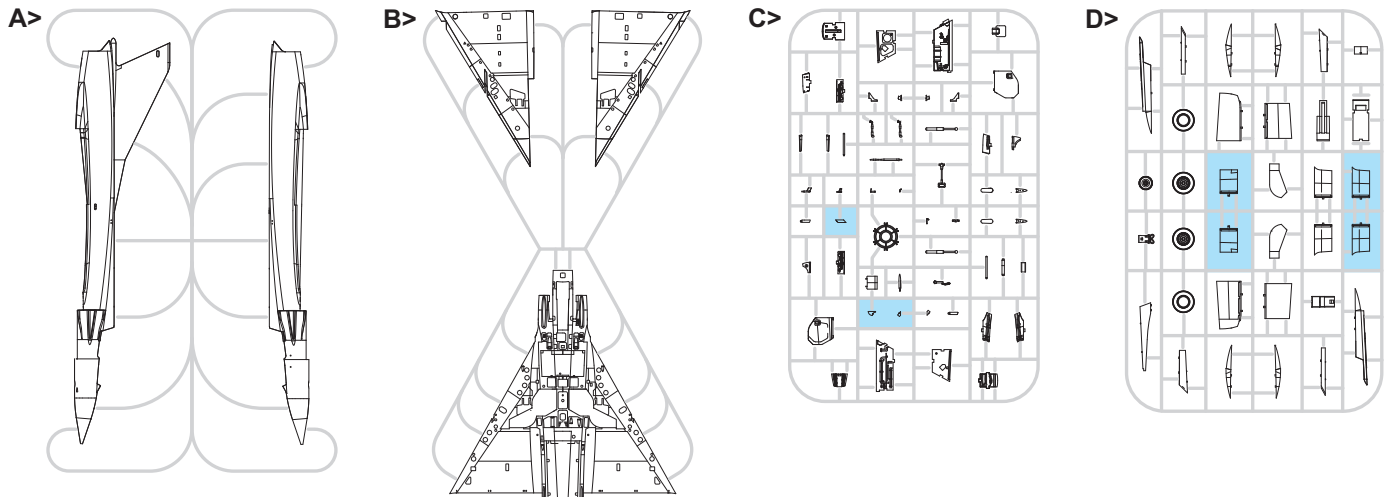
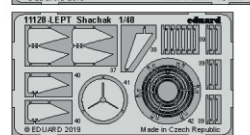
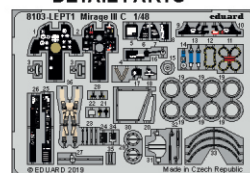
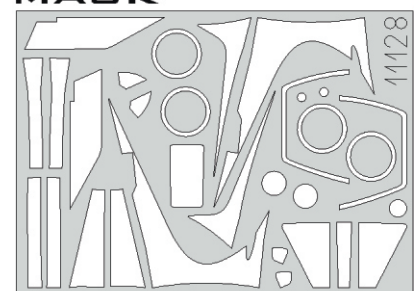
PE - PHOTO ETCHED
DETAIL PARTSeduard
MASK

RP - RESIN PARTS



RP28

RP29

RP30

RP31

-Parts not for use. -Teile werden nicht verwendet. -Pièces à ne pas utiliser. -Tyto díly nepoužívejte při stavbě. - 使用しない部品

COLOURS



BARVY



FARBEN



PEINTURE



色

GSI Creos (GUNZE)		MISSION MODELS	
AQUEOUS	Mr.COLOR	PAINTS	
[H1]	[C1]	[MMP-001]	WHITE
[H2]	[C2]	[MMP-047]	BLACK
[H3]	[C3]	[MMP-003]	RED
[H4]	[C4]	[MMP-007]	YELLOW
[H8]	[C8]		SILVER
[H11]	[C62]	[MMP-001]	FLAT WHITE
[H12]	[C33]	[MMP-047]	FLAT BLACK
[H52]	[C12]	[MMP-091]	OLIVE DRAB
[H77]	[C137]	[MMP-040]	TIRE BLACK
[H90]	[C47]		CLEAR RED
[H93]	[C50]		CLEAR BLUE
[H94]	[C138]		CLEAR GREEN
[H305]	[C305]	[MMP-084]	GRAY

GSI Creos (GUNZE)		MISSION MODELS	
AQUEOUS	Mr.COLOR	PAINTS	
[H307]	[C307]	[MMP-074]	GRAY
[H308]	[C308]	[MMP-073]	GRAY
[H310]	[C310]	[MMP-060]	BROWN
[H312]	[C312]		GREEN
[H313]	[C313]		YELLOW
[H314]	[C314]		BLUE
Mr.METAL COLOR		METALLICS	
[MC213]		[MMM-006]	STEEL
[MC214]		[MMM-001]	DARK IRON
[MC218]		[MMM-003]	ALUMINIUM
Mr.COLOR SUPER METALLIC		METALLICS	
[SM01]		[MMC-001]	SUPER CHROME
[SM03]		[MMM-002]	SUPER IRON

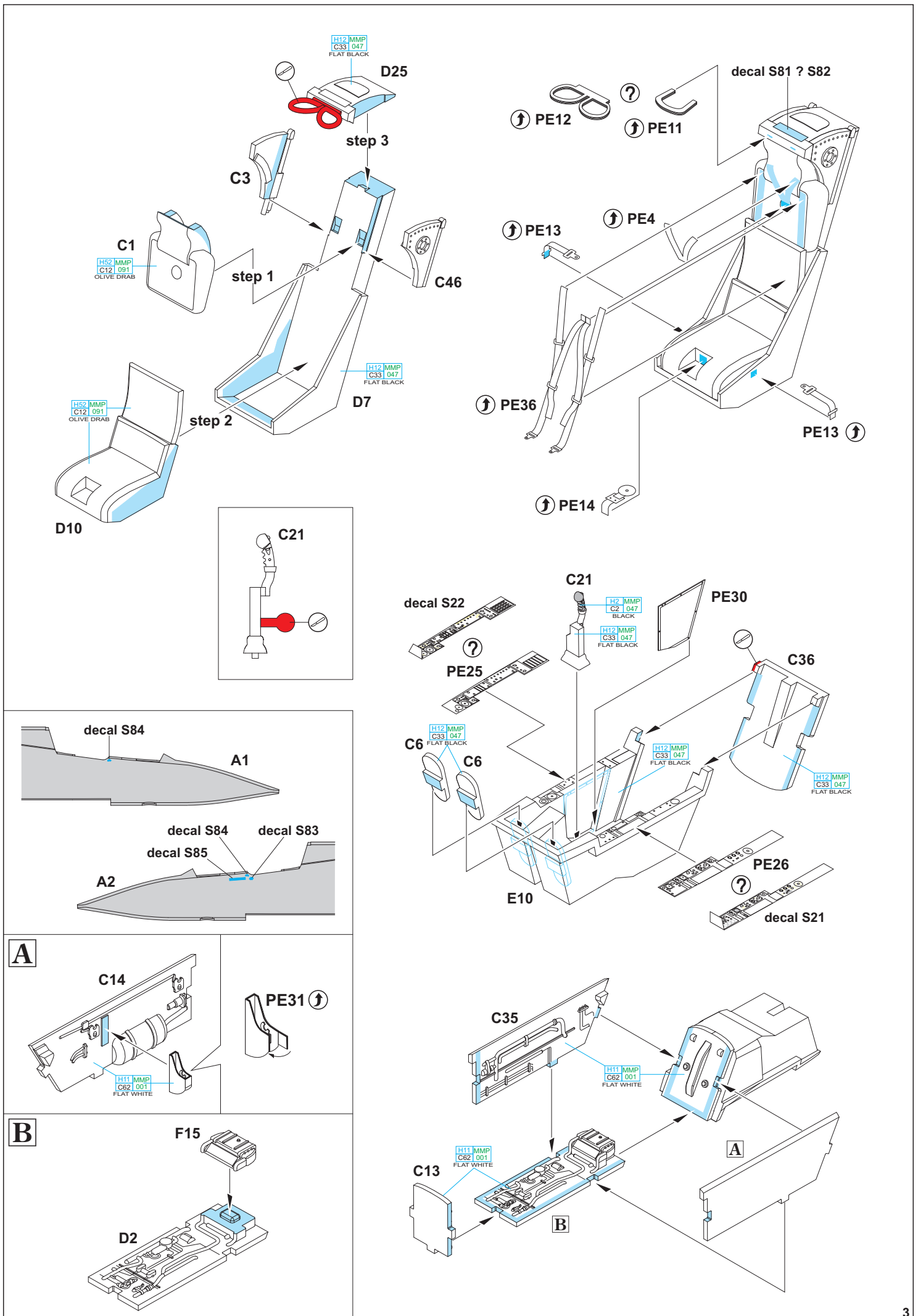

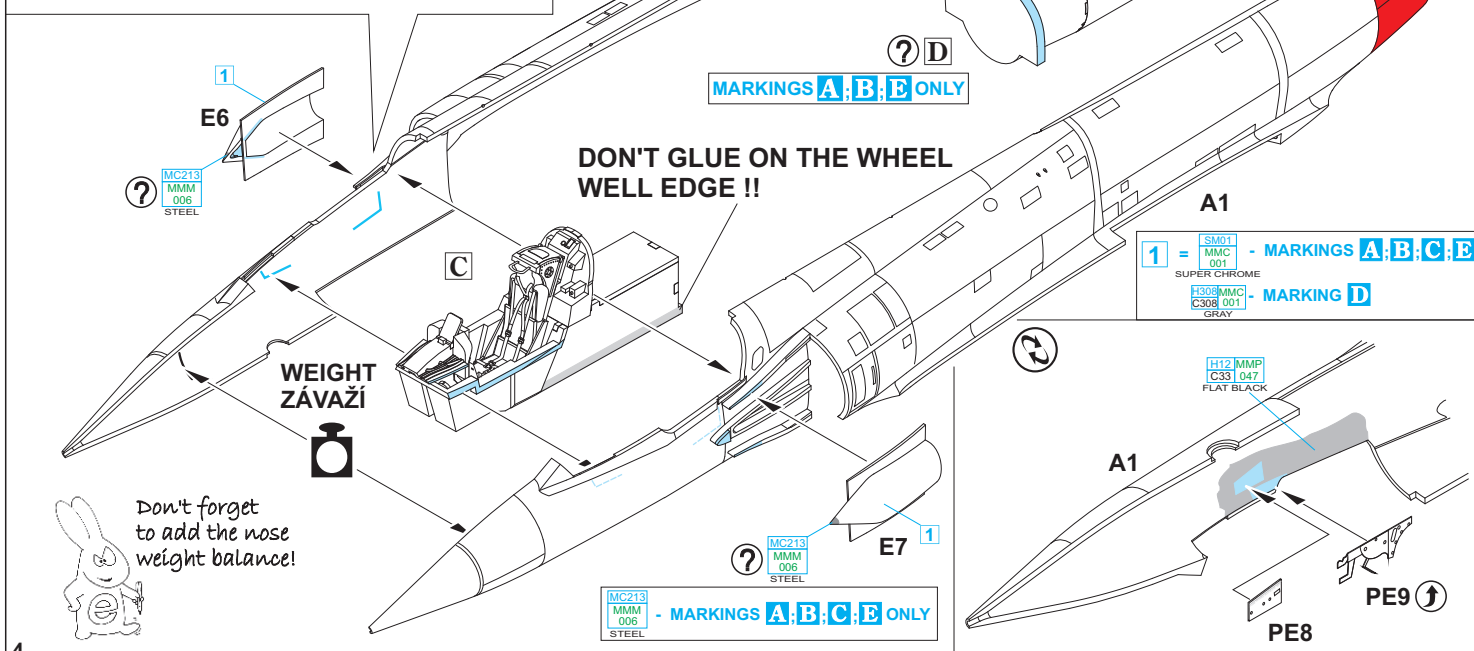
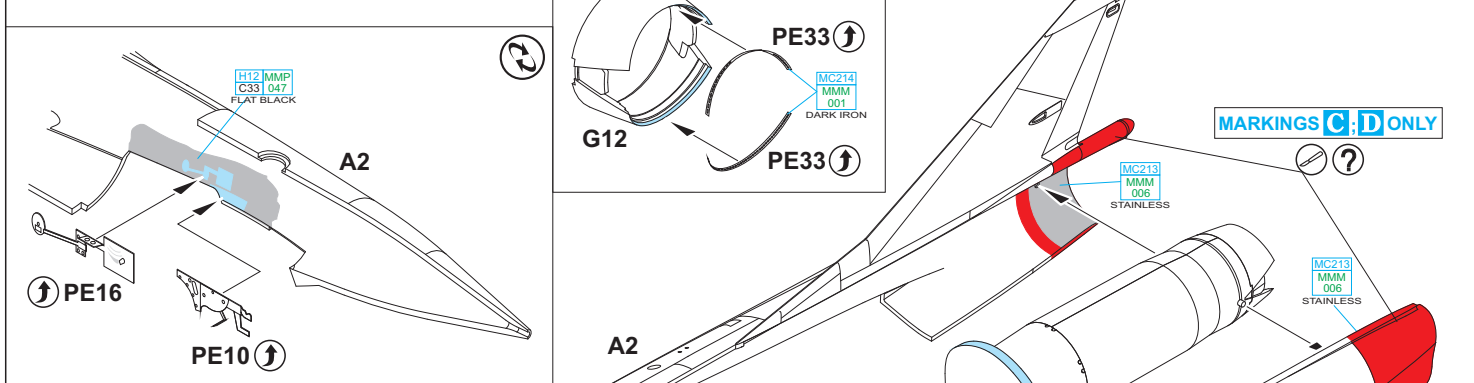
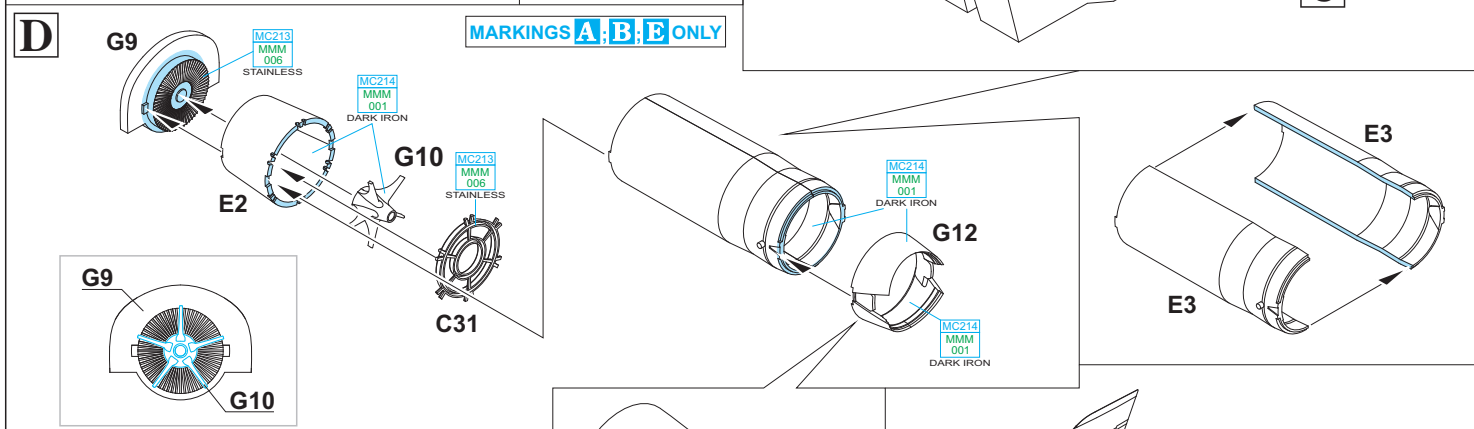
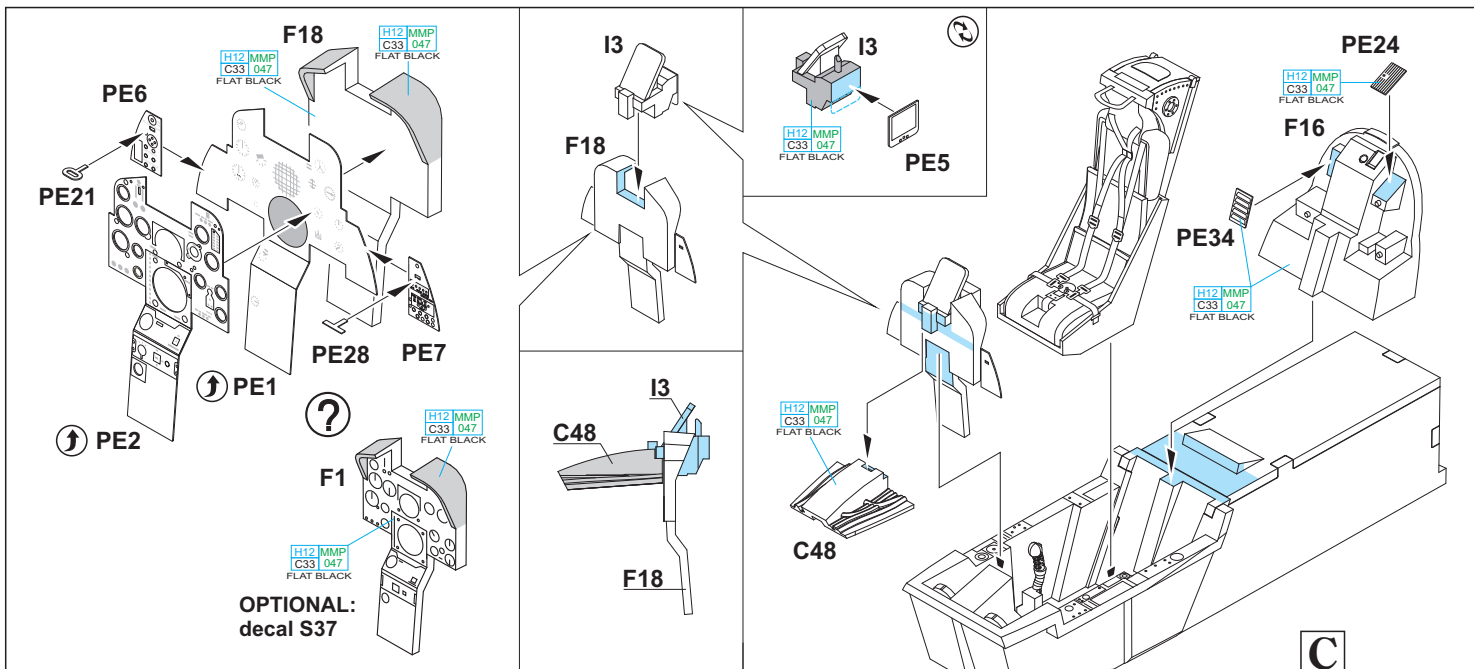

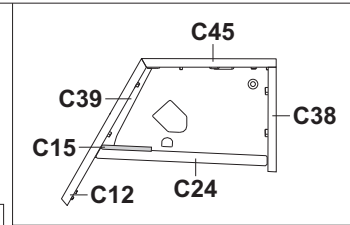
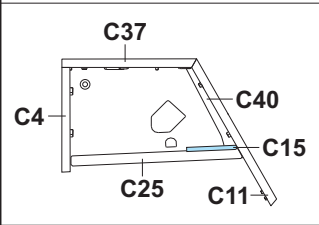
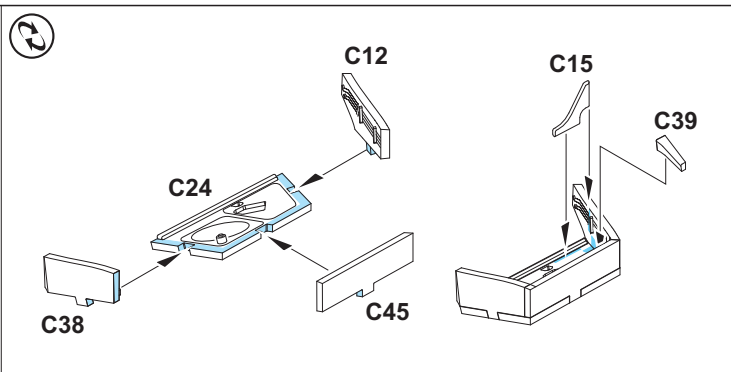
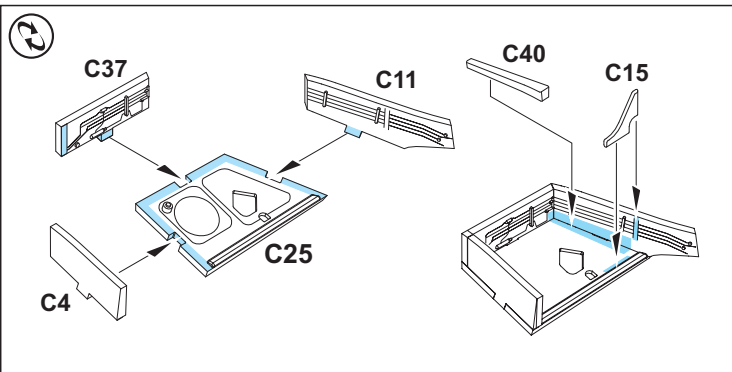

FOR EXTERNAL FUEL TANKS
RACKS D6 OR D11
SEE PAGE 13

MARKINGS B, E ONLY
FOR MATRA 530
RACK D26
SEE PAGE 13

FOR EXTERNAL FUEL TANKS
RACKS D6 OR D11
SEE PAGE 13

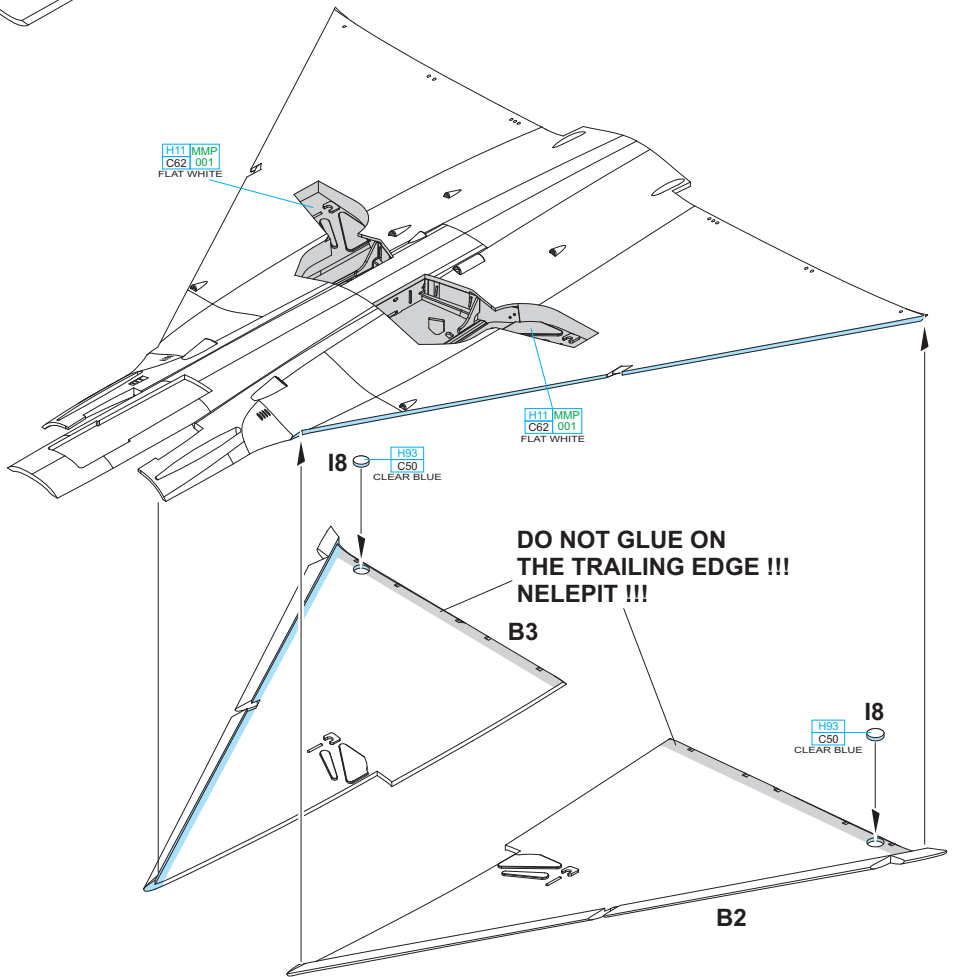
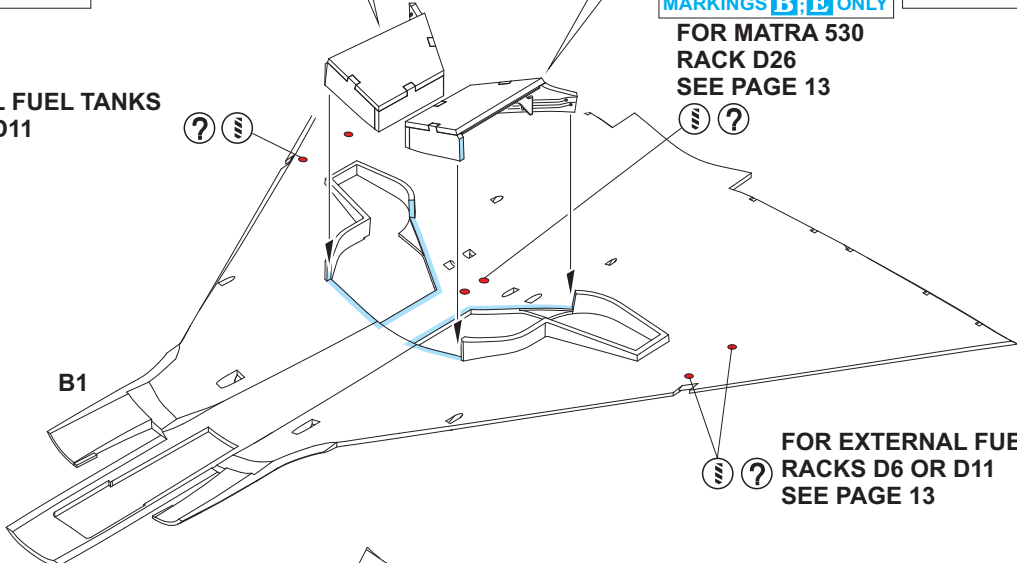

H11 MMP
C62 001
FLAT WHITE

H11 MMP
C62 001
FLAT WHITE

I8
H93
C50
CLEAR BLUE

**DO NOT GLUE ON
THE TRAILING EDGE !!!
NELEPIT !!!**

I8
H93
C50
CLEAR BLUE

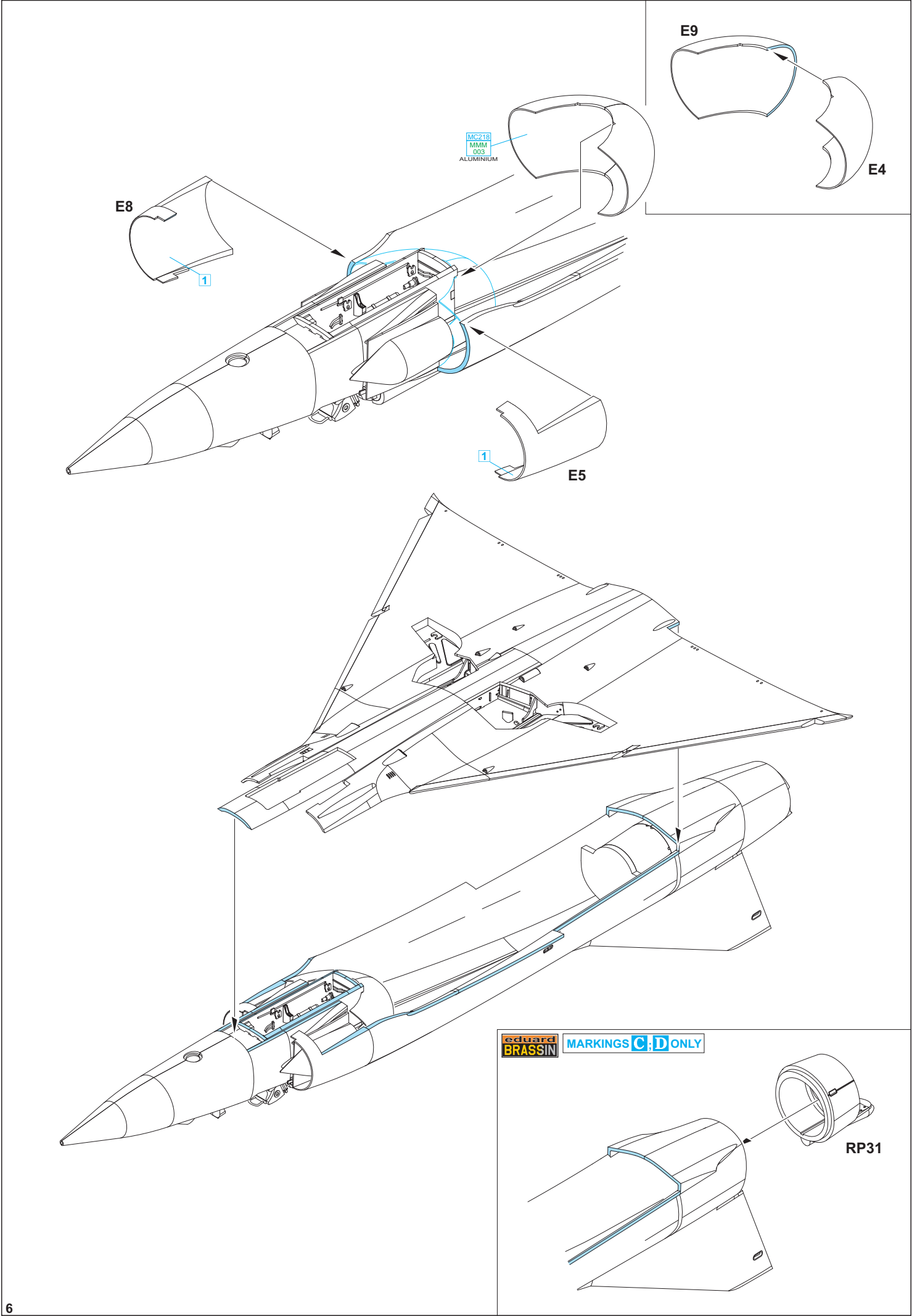

E9

E4

MC218
MMT
002
ALUMINIUM

E8

1

1

E5

eduard
BRASSIN MARKINGS C; D ONLY

RP31

USE D5 FOR AIM-9D SIDEWINDER (PART G2)
SEE PAGE 13

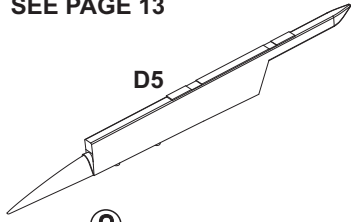

?

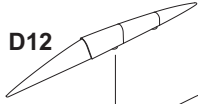

D12

D17

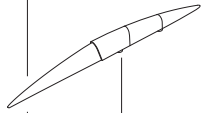

H3

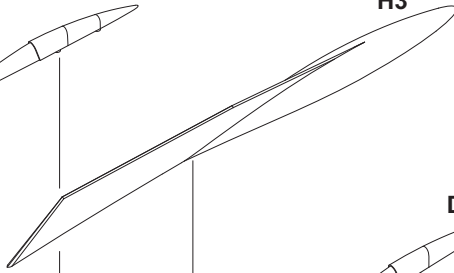

D17

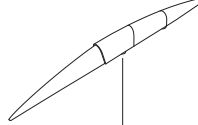

D12



?

USE D5 FOR AIM-9D SIDEWINDER (PART G2)
SEE PAGE 13

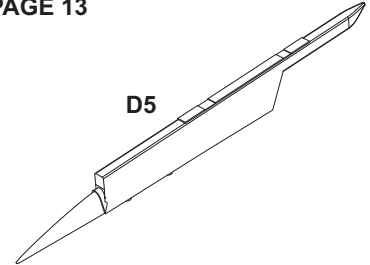

D5

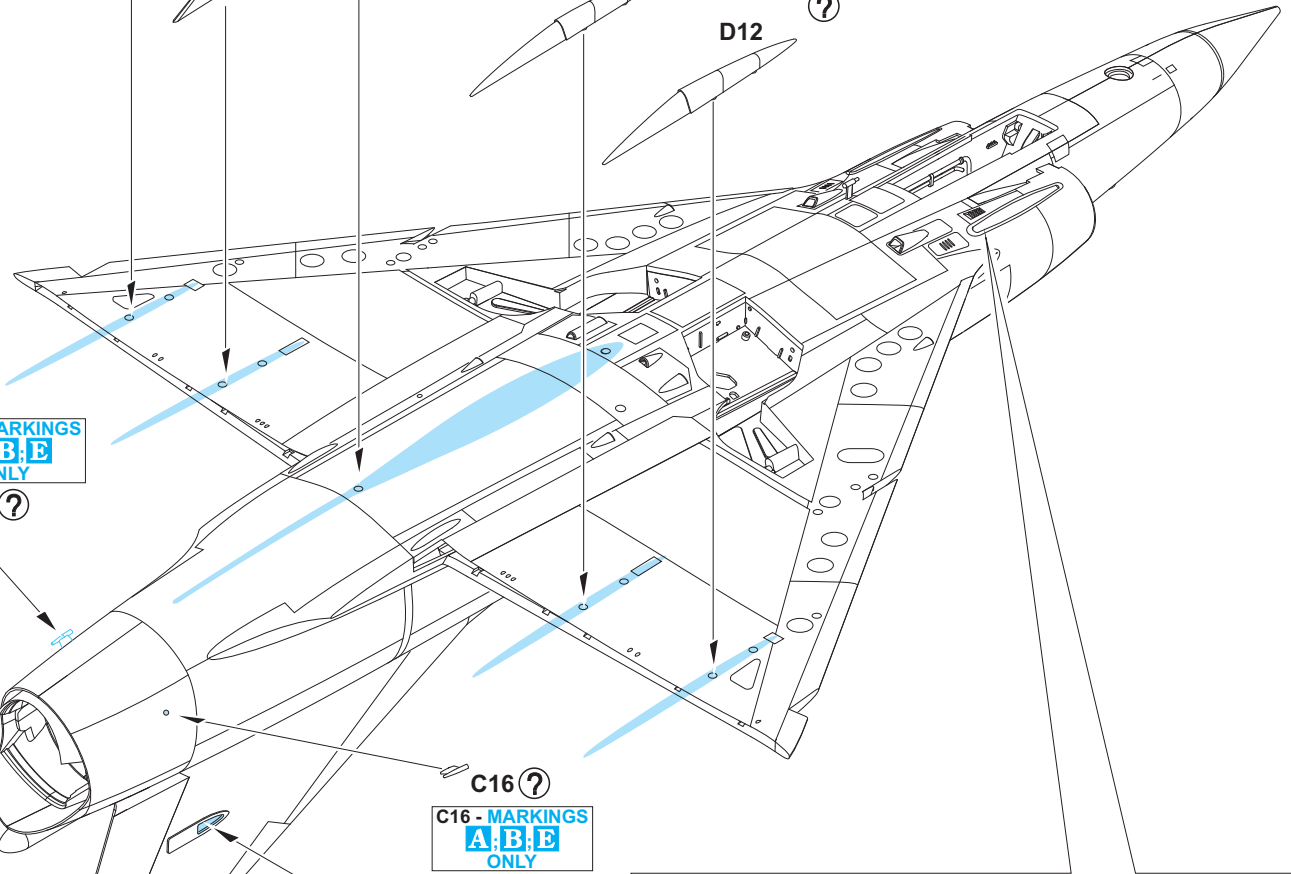

C16 - MARKINGS
A, B, E
ONLY

C16 ?



C16 ?

C16 - MARKINGS
A, B, E
ONLY

C32



CLEAR FIX ? I9

?

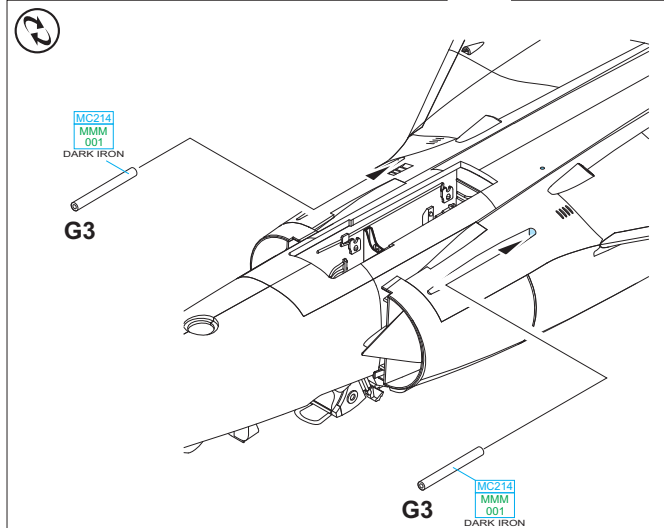
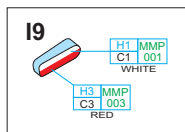

?

MC214
MMM
001
DARK IRON

G3

G3

MC214
MMM
001
DARK IRON

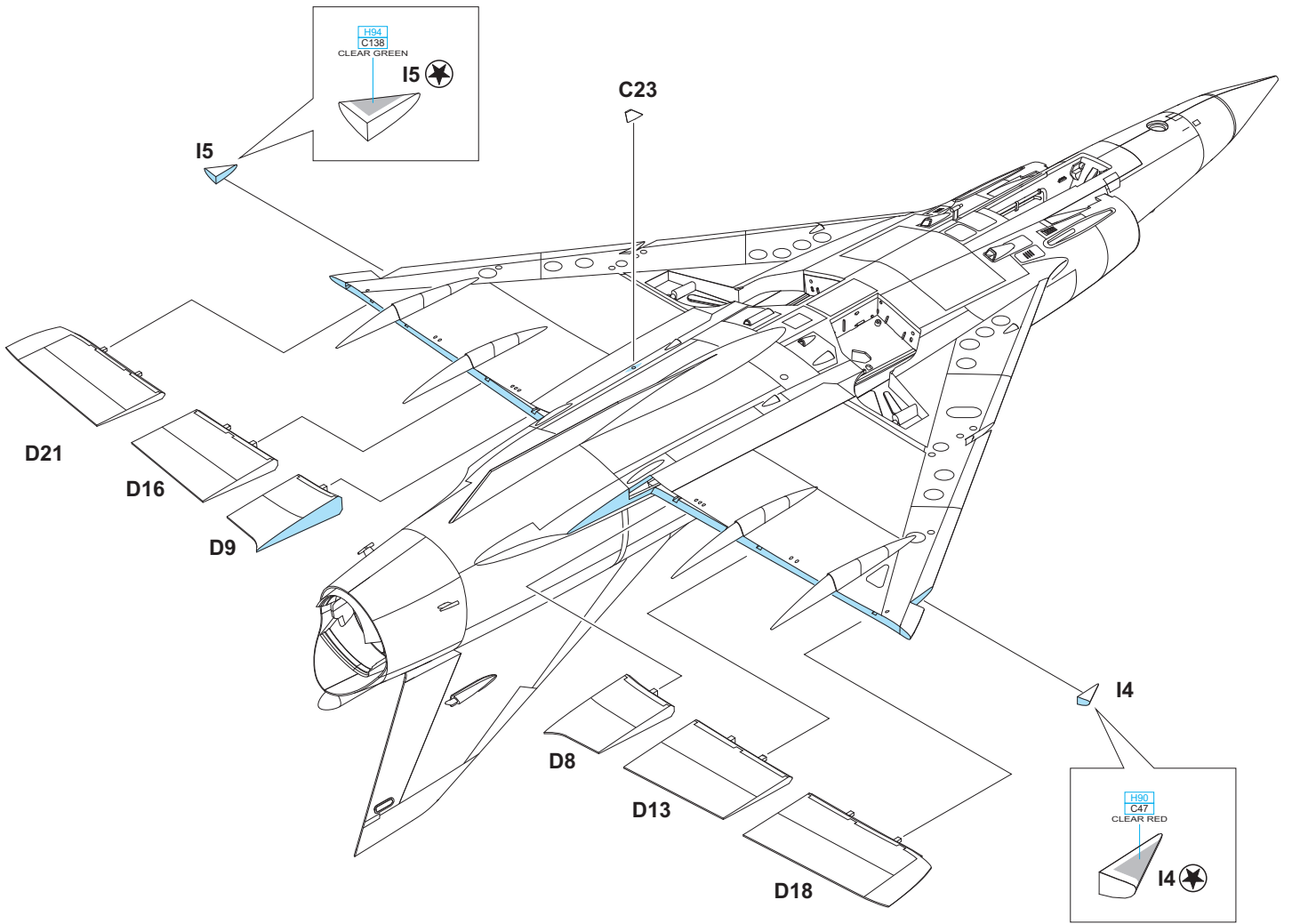

eduard
BRASSIN MARKINGS C; D ONLY

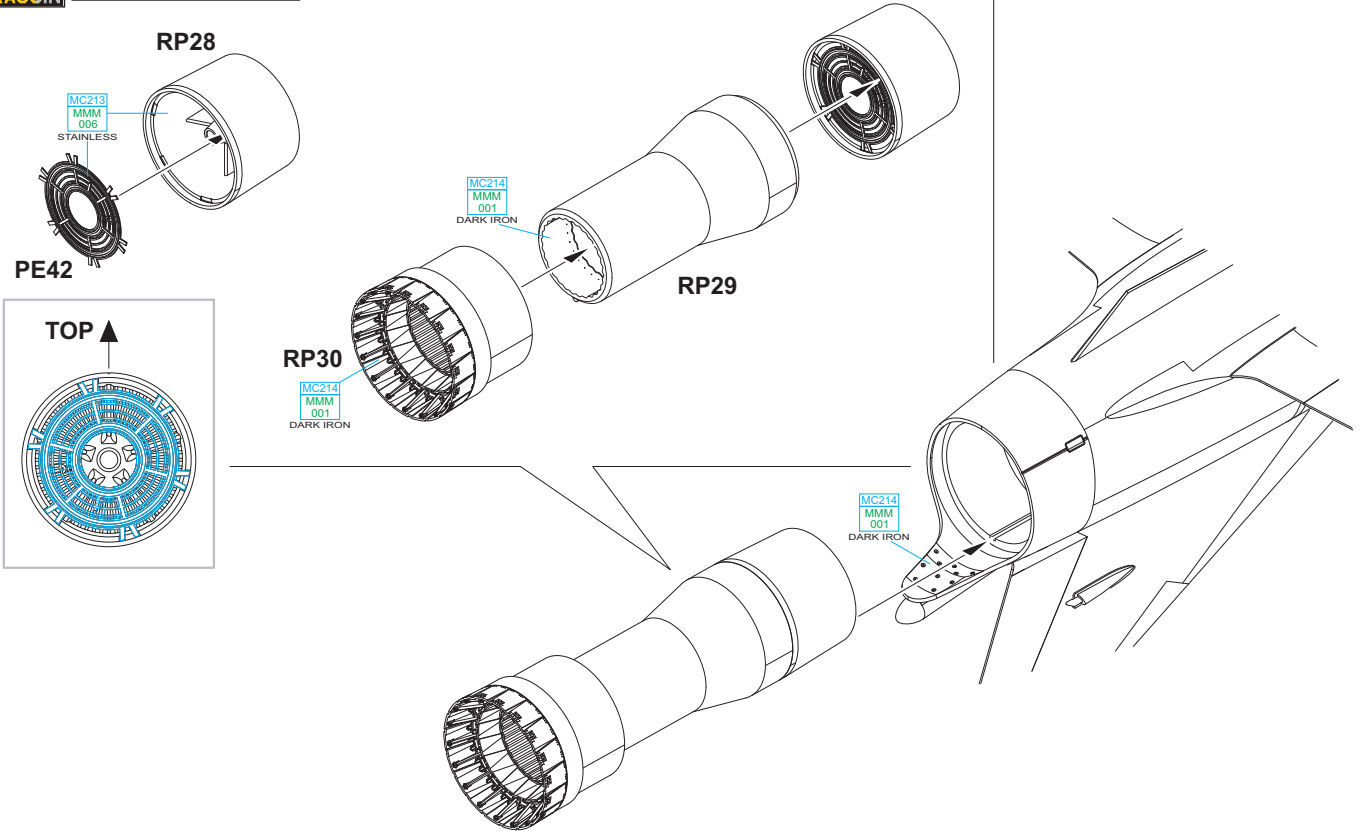

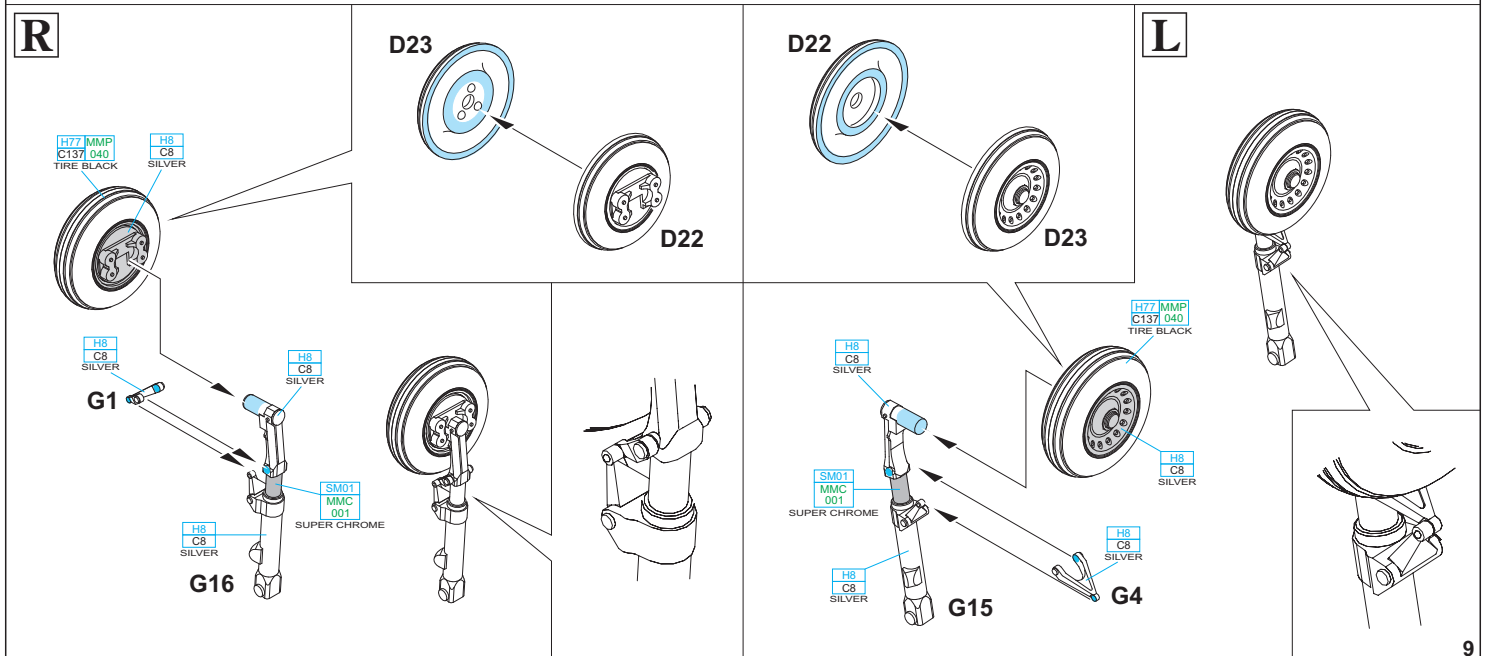
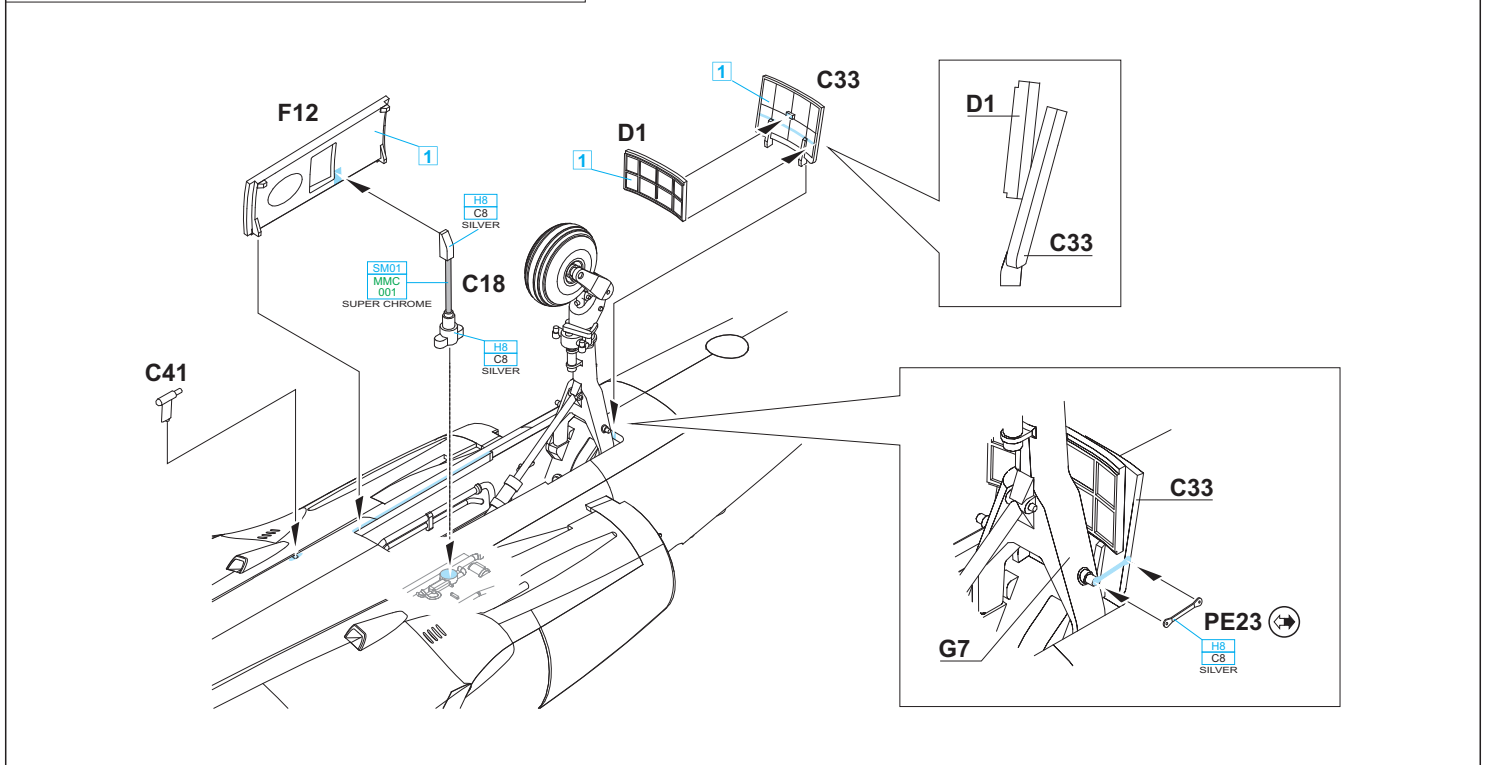
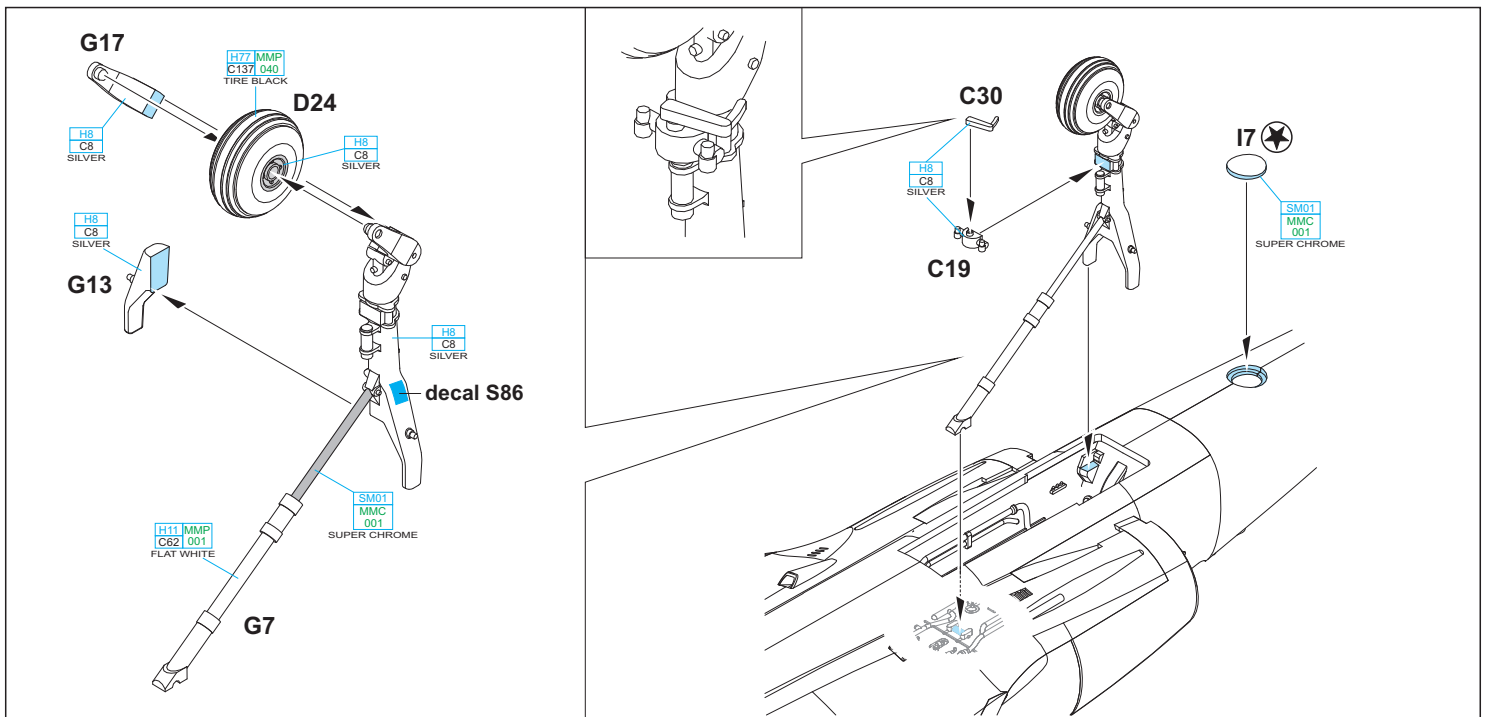

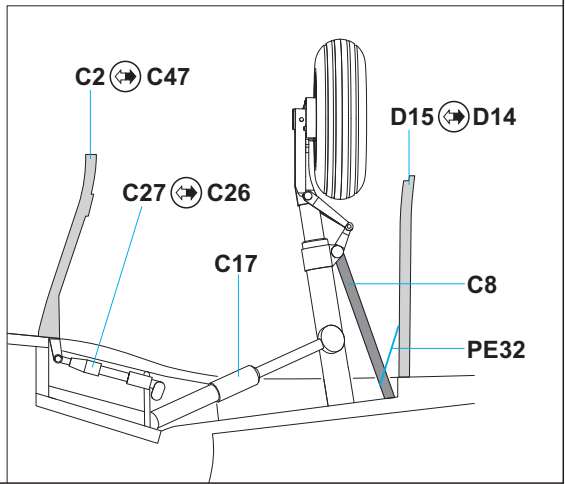
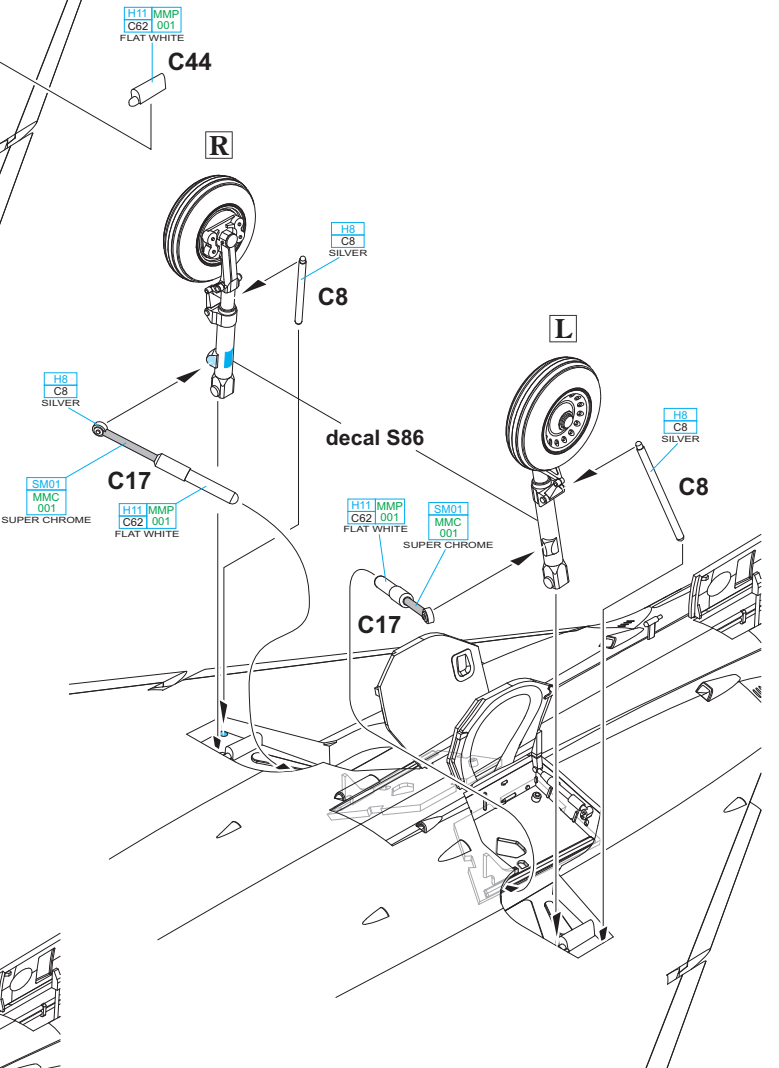
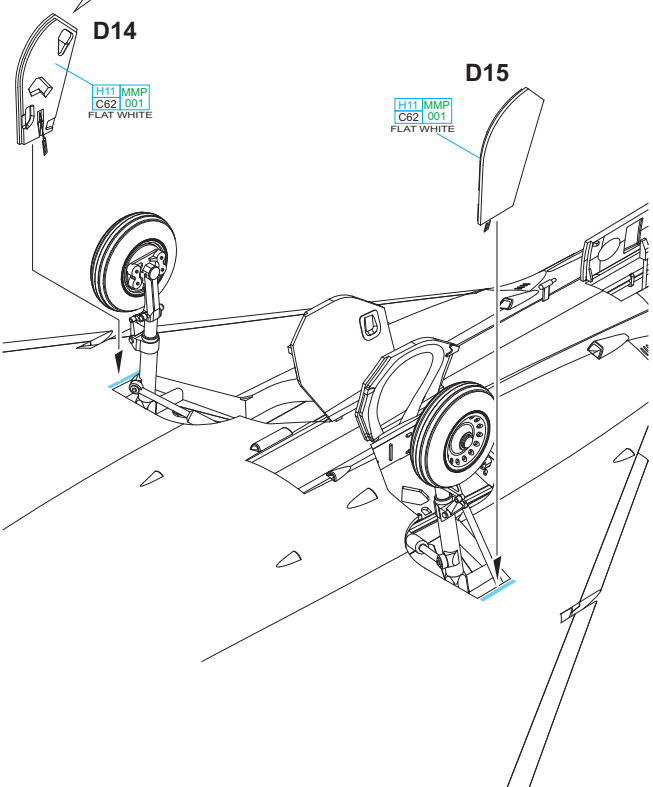
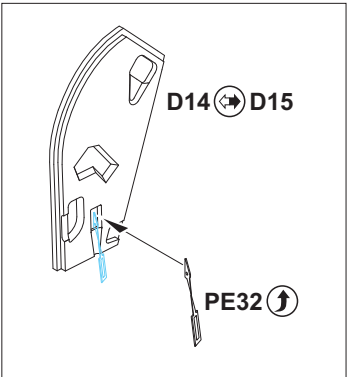
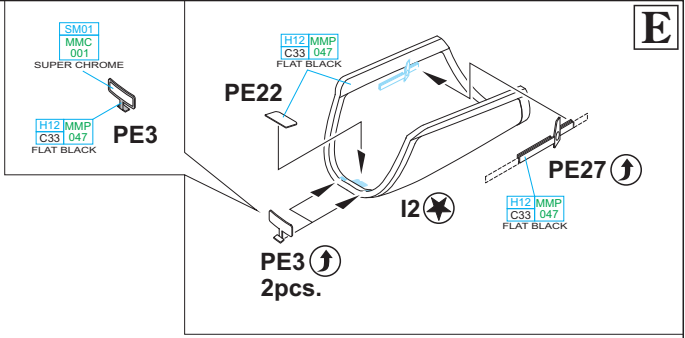
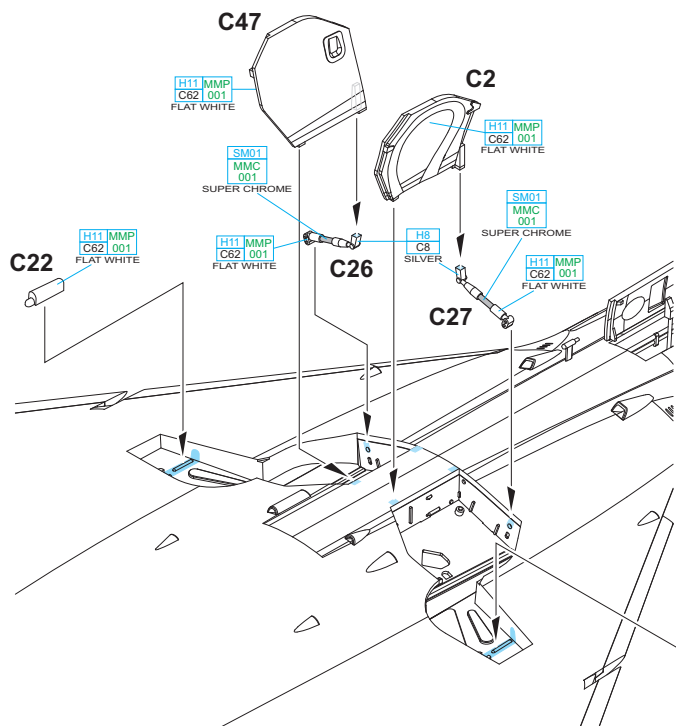

PE38 ? PE38 - MARKING C ONLY

CLOSED E

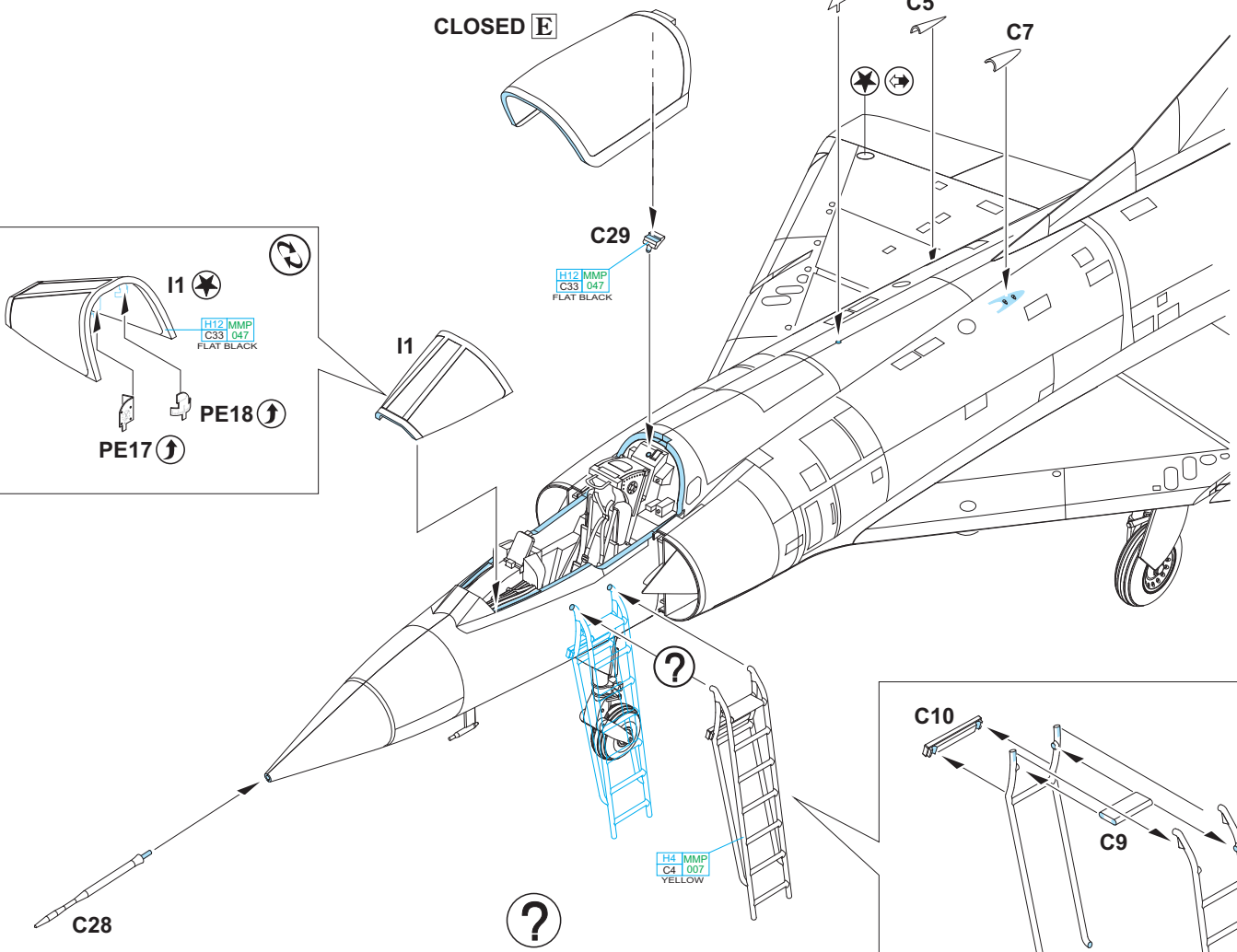

?

OPEN E

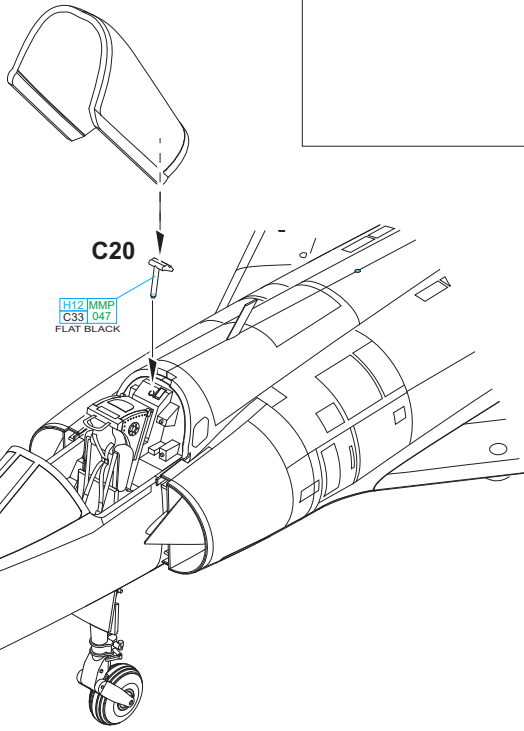
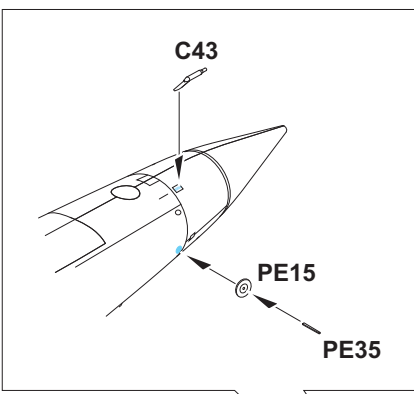

F EXTERNAL FUEL TANK- 625I
2 pcs.

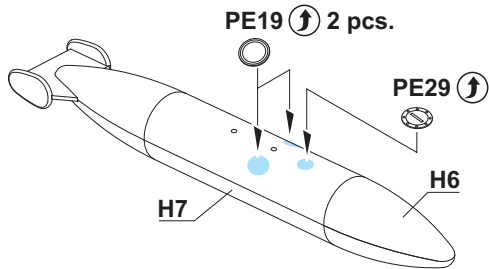
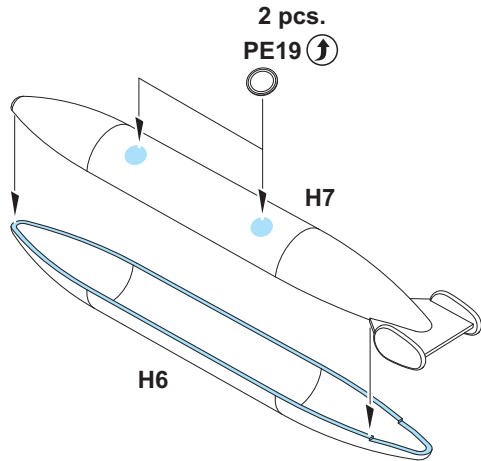

G EXTERNAL FUEL TANK- 500I
2 pcs.

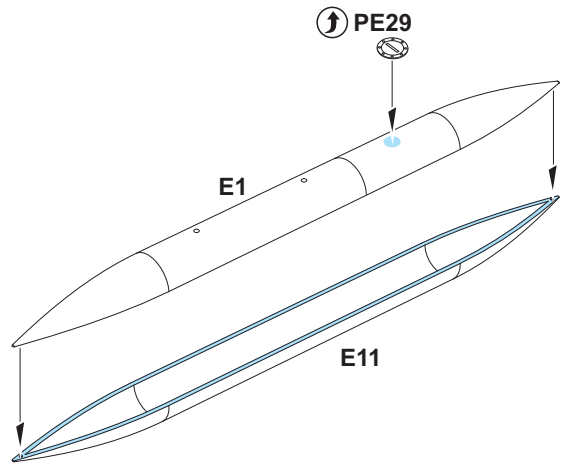

DO NOT GLUE!

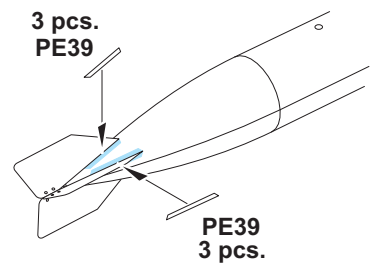
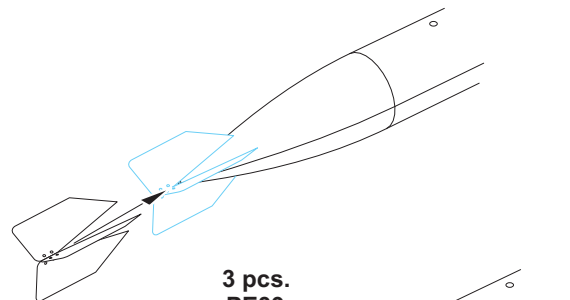
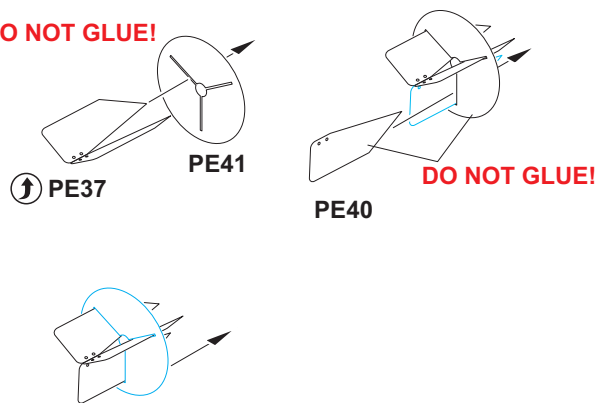

H MATRA 530C,K

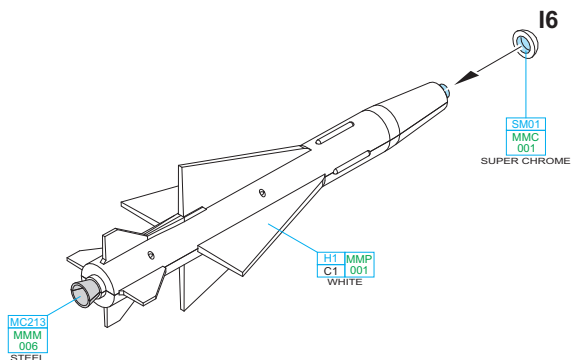
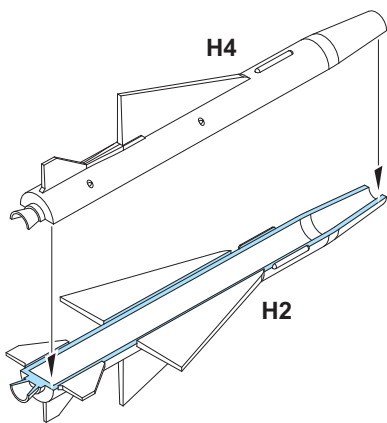

I AIM-9D SIDEWINDER
2 pcs.

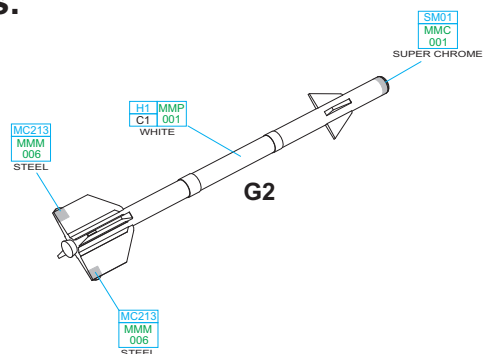

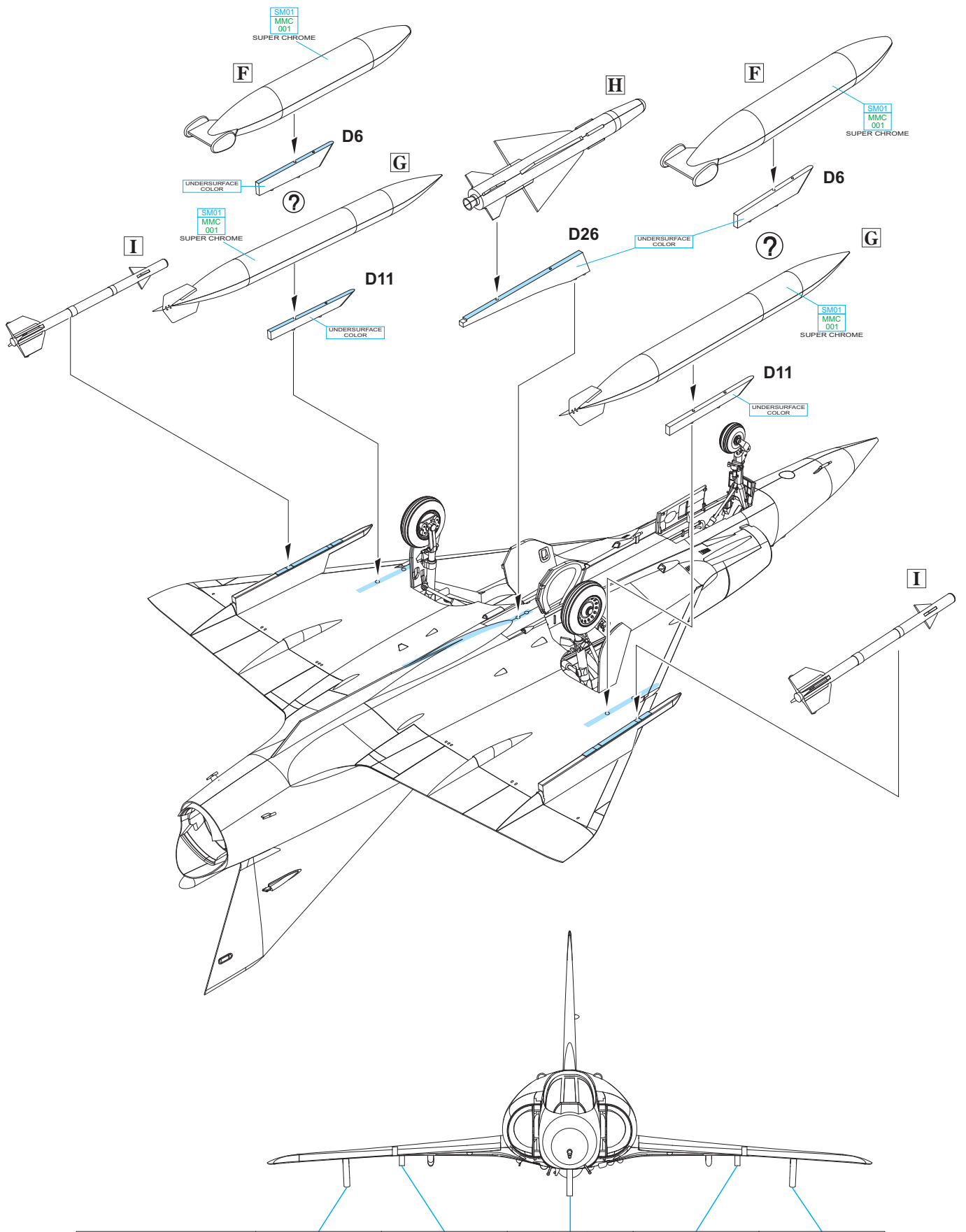

MATRA 530C, K			✕		
FUEL TANK 5001		○		○	
FUEL TANK 625I		○		○	
AIM-9D SIDEWINDER	✕				✕

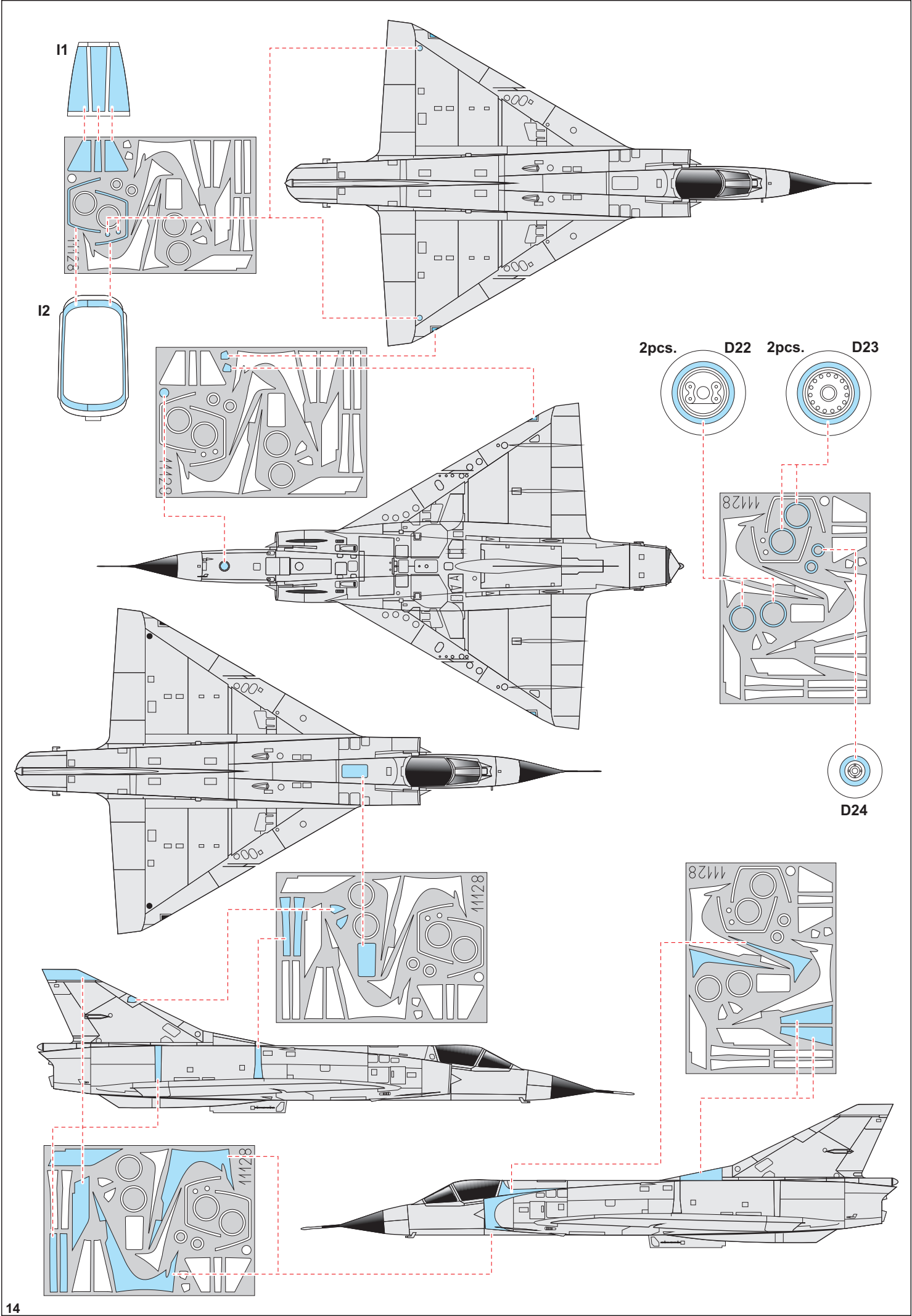

A č. 177, 117. tajeseť, letecká základňa Ramat David, Izrael, 1977

Kamuflovaný Šachak č. 177 od 117. tajeseť ze základny Ramat David v podobe z roku 1977. Výrazné černožluté trojuhelníky byly zavedeny během Jomkipurské války. Zajímavostí je pět symbolů sestřelů syrských letounů pod kabinou (tři hvězdičky v bílém mezikruží). Ve skutečnosti sestřelili izraelští piloti v kabině tohoto letounu 5 egyptských letounů a jeden syrský. Sestřel egyptského letounu se označoval dvěma hvězdičkami v bílém mezikruží. Příčina záměny symbolů není známa.

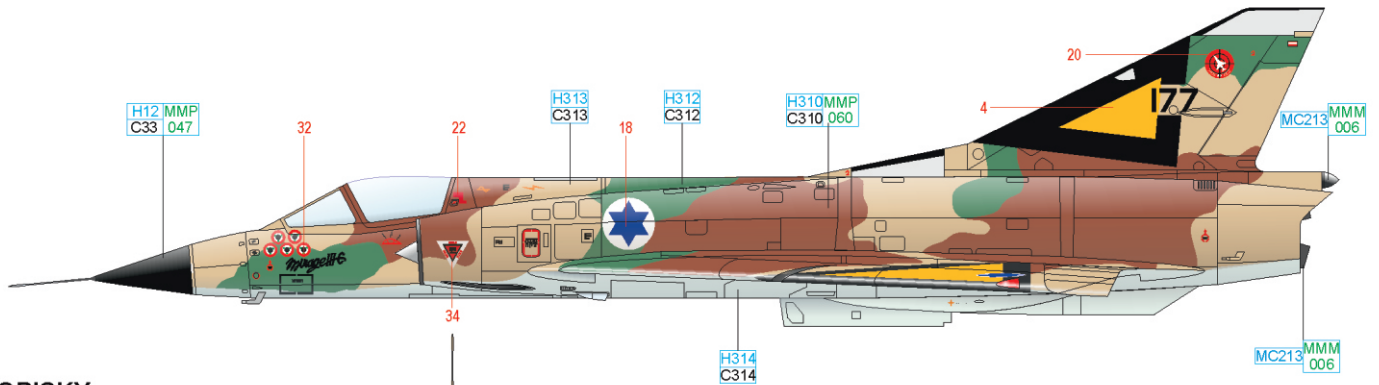

POPISKY:

S1, S2, S3, S4, S5, S8, S9, S15, S18, S19, S20, S23, S24, S29, S30, S31, S33, S34, S35, S36, S38, S39, S40, S41, S42, S43, S46, S47, S48, S49, S50, S51, S52, S53, S54, S55, S56, S61, S62, S63, S64, S65, S66, S67, S68, S69, S71, S72, S77

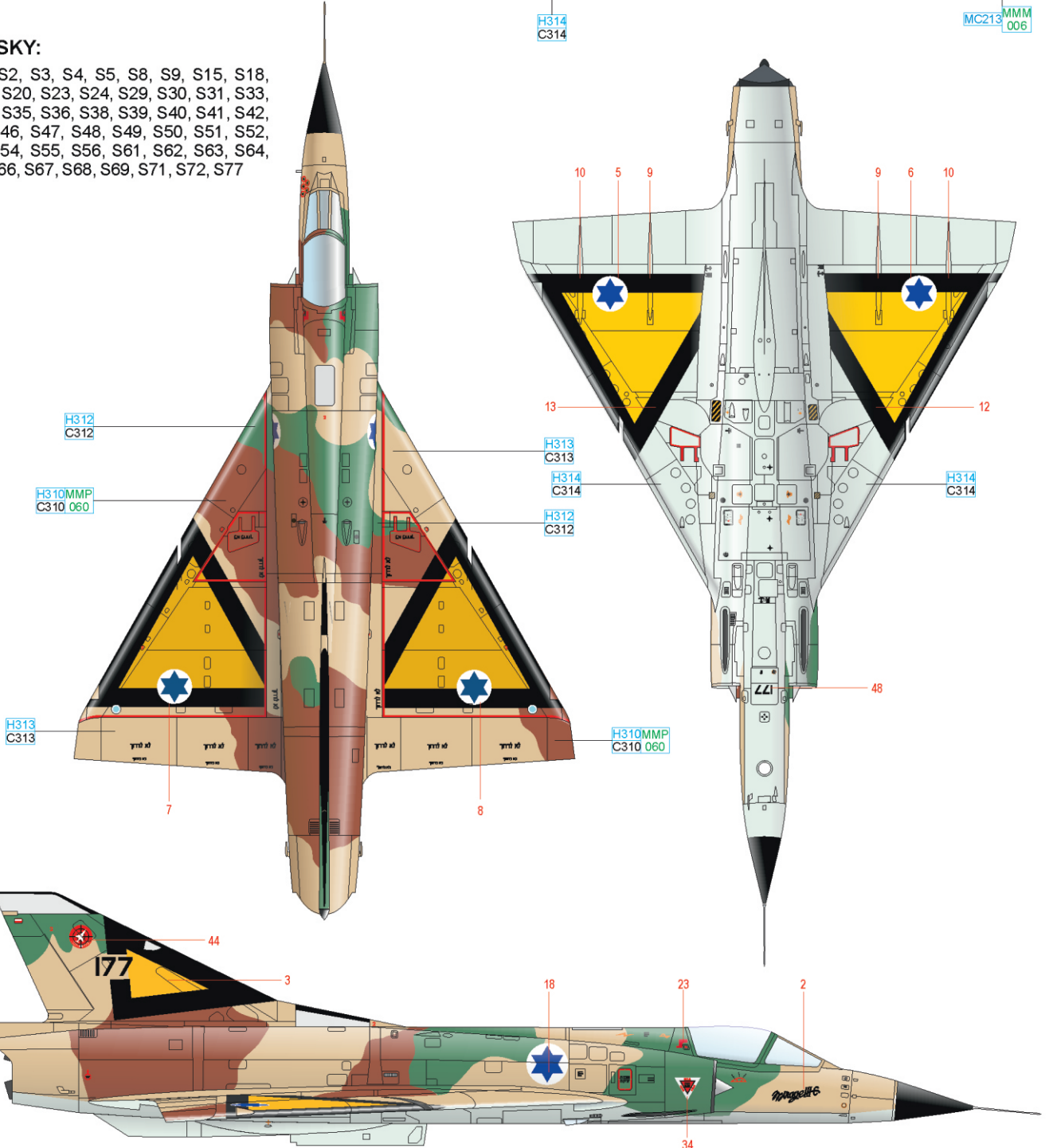

BLACK	H12 MMP C33 047	STEEL	MC213 MMM 006
BROWN	H310MMP C310 060	GREEN	H312 C312
		YELLOW	H313 C313
		LIGHT BLUE	H314 C314

B č. 70, 117. tajaset, letecká základna Ramat David, Izrael, červen 1967

Šachak č. 70 od 117. tajaset ze základny Ramat David létal v této podobě těsně po skončení Šestidenní války. Za řízením tohoto letounu nárokovali izraelští piloti celkem čtyři sestřely. Dva syrské MiGy-21 během Šestidenní války a následně dvojici egyptských MiGů-21 během Opatřebovací války. Letoun byl sestřelen 2. března 1970 a jeho pilot Itamar Neuner se katapultoval. Izraelské zdroje udávají jako příčinu protiletadlovou palbu ze země, dle egyptských byl letoun sestřelen nadporučíkem Ali Wagedym v MiGu-21.

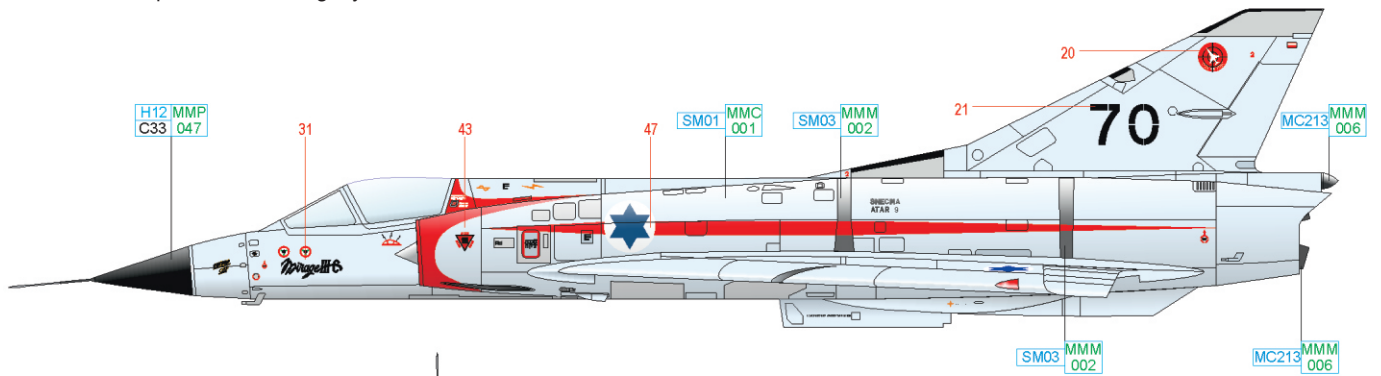

POPISKY:

S1, S2, S4, S5, S6, S7, S10, S11, S12, S13, S14, S15, S16, S17, S18, S23, S24, S25, S26, S27, S28, S29, S30, S31, S32, S33, S34, S35, S36, S38, S39, S42, S43, S46, S47, S49, S50, S51, S52, S53, S54, S55, S56, S57, S58, S59, S61, S62, S63, S64, S65, S66, S67, S68, S70, S71, S72, S73, S75, S76, S78

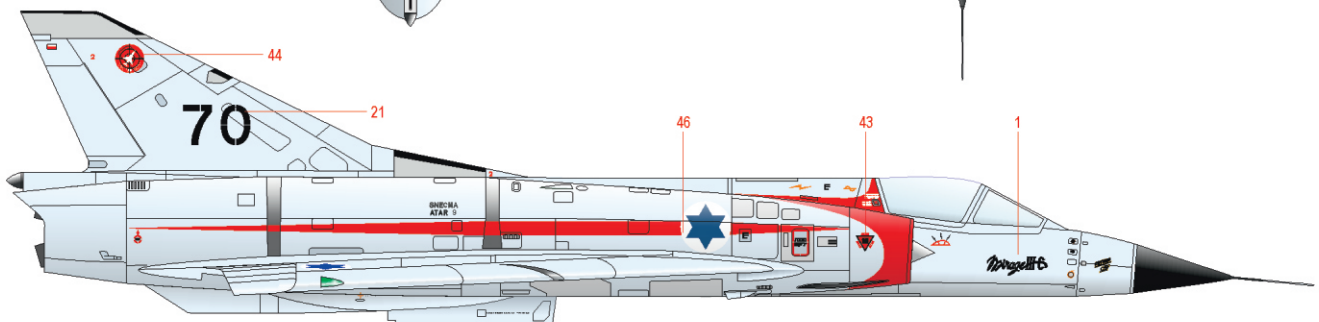
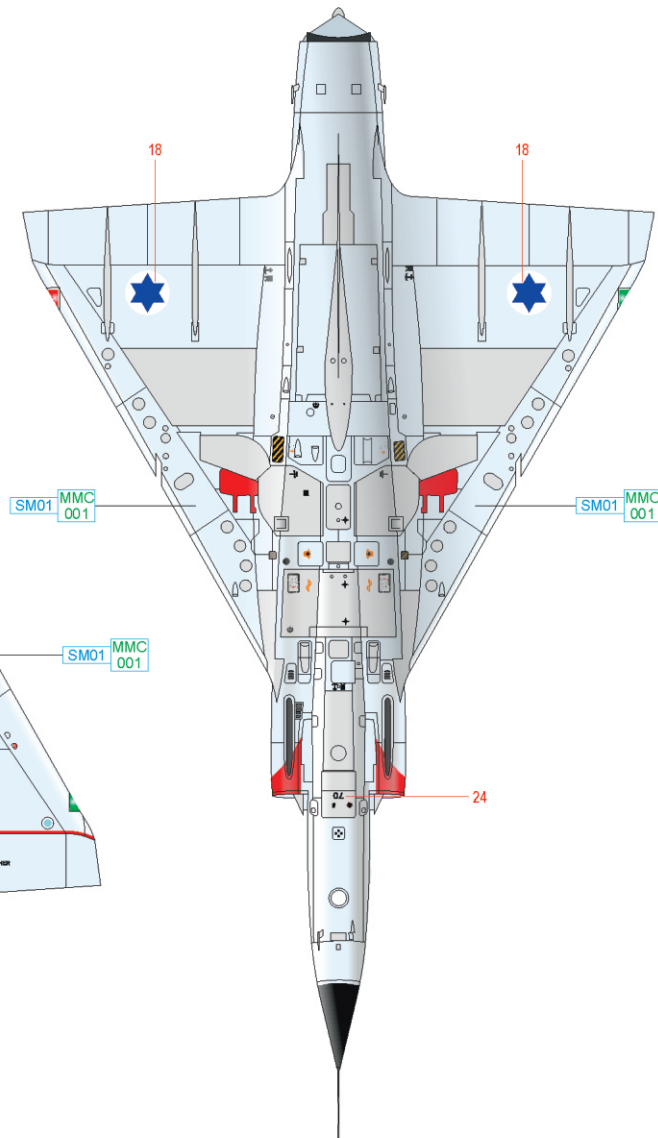
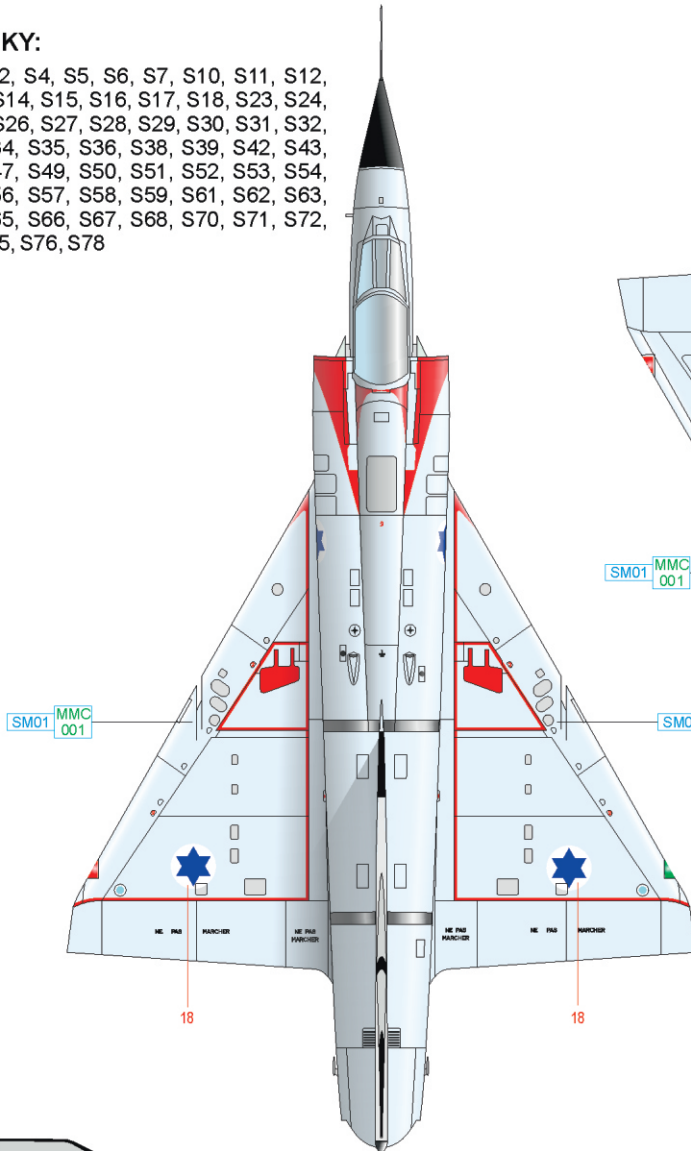

C č. 778, 101. tajeset, letecká základna Hacor, Izrael, 1972

Šachak č. 778 v barvách 101. tajeset v podobě na konci roku 1972, kdy měl již na kontě 8,5 sestřelu místo 8 nakreslených pod kabinou. Jedná se o první letoun konvertovaný na motor Atar 9C. Celkové skóre tohoto letounu činí 10,5 sestřelu (jedná se také o letoun s nejvyšším počtem sestřelů dosažených během Šestidenní války). Byl ztracen 10. října 1973 během Jomkipurské války v souboji se syrskými MiGy-17, jeho pilot Ejtan Karmi se katapultoval. Kamuflované stroje byly na horních plochách nastříkány pískovou FS 33531, hnědou FS 30219 a zelenou FS 34227, spodní plochy byly světle modré FS 35622.

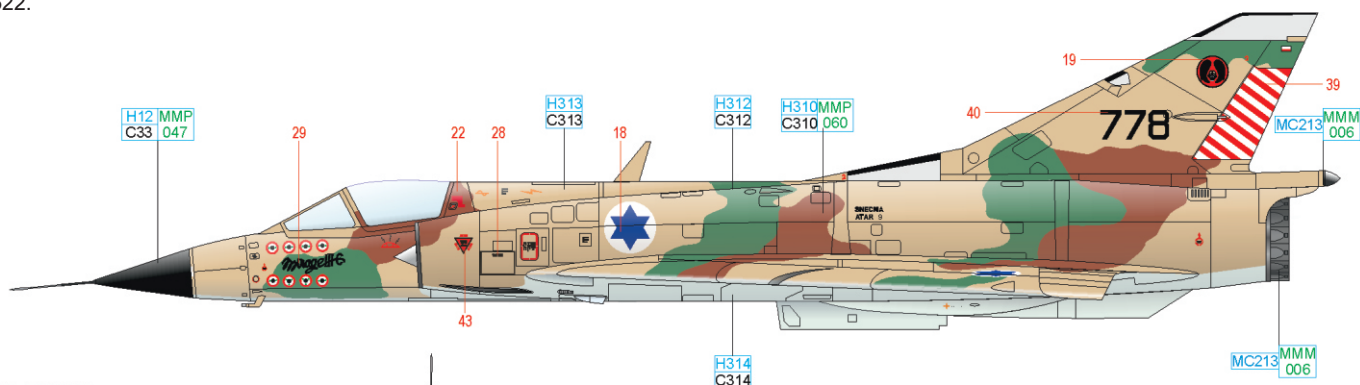

POPISKY:

S1, S2, S3, S4, S5, S8, S9, S10, S15, S18, S19, S20, S23, S24, S29, S30, S31, S33, S34, S35, S36, S38, S39, S40, S41, S42, S43, S46, S47, S48, S49, S50, S51, S52, S53, S54, S55, S56, S61, S62, S63, S64, S65, S66, S67, S68, S69, S71, S72, S77

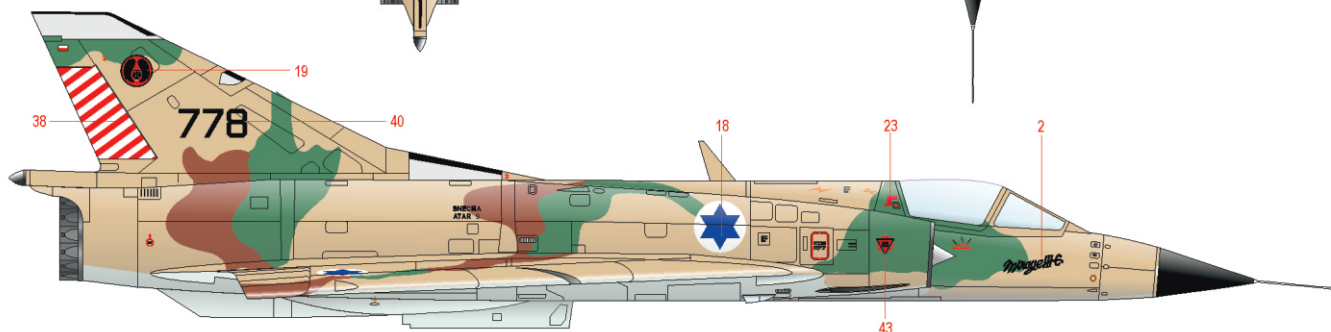
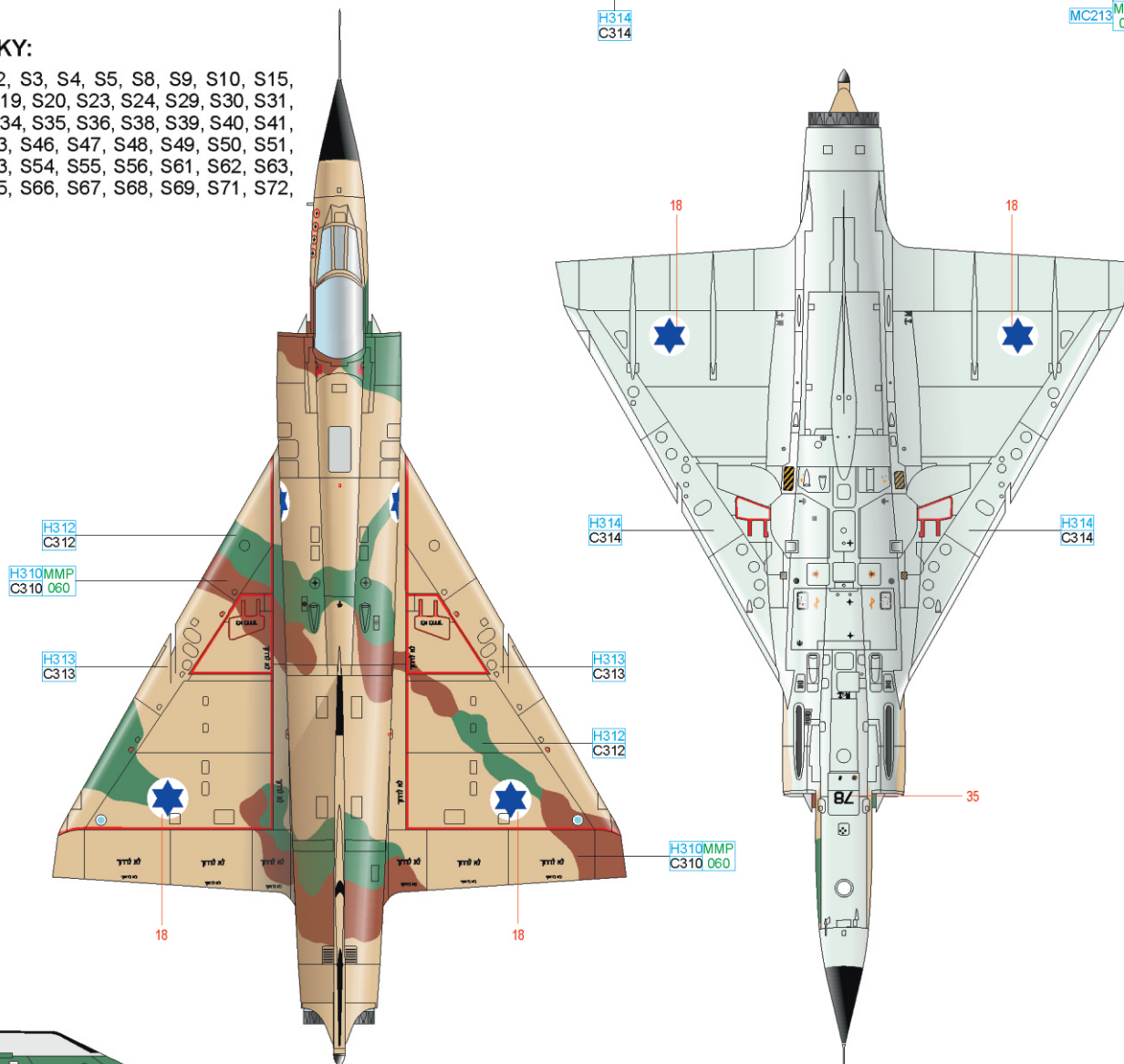

BLACK	H12 MMP C33 047	STEEL	MC213 MMM 006
BROWN	H310MMP C310 060	GREEN	H312 C312
		YELLOW	H313 C313
		LIGHT BLUE	H314 C314

D č. 153, 253. tajaset, letecká základna Ejtam, Izrael, 1980

Jeden ze tří Šachaků, které byly na konci služby v Izraeli opatřeny nátěrem nazývaným Air-superiority, tvořeným šedými barvami FS 36375 a FS 36320, byl i stroj č. 153 s motorem Atar 9C (dalšími dvěma byly č. 103 a 144). Letoun původně sloužil u 119. tajaset, kde byl v roce 1963 přestavěn na průzkumnou variantu, ale v témže roce s ním havaroval Ran Ronen. Do služby až po pět let trvající opravě, ale v původní stíhací podobě. Byl zařazen do stavu 117. tajaset, jejíž piloti v jeho kabině dosáhli tří sestřelů. V roce 1979 putoval k 253. tajaset a poté k 254., u které sloužil až do roku 1982, kdy byl prodán do Argentiny, kde létal jako C-710 až do vyřazení v září 1985.

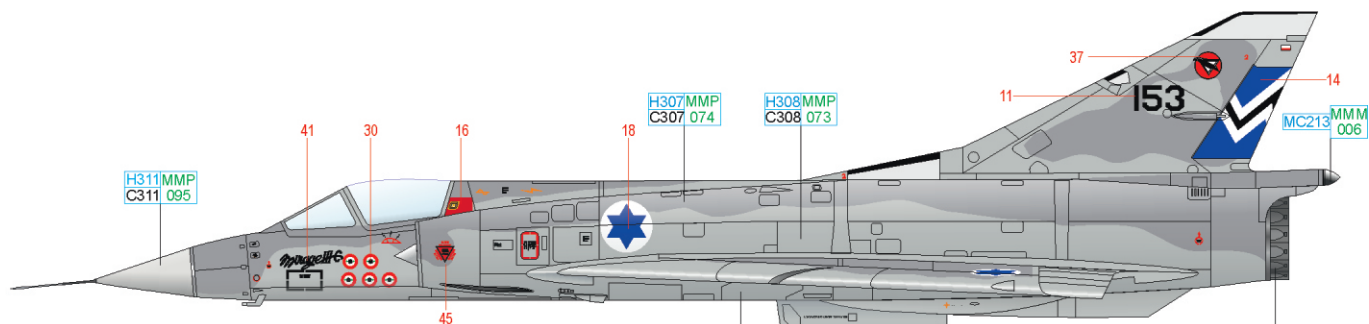

POPISKY:

S1, S2, S3, S4, S5, S8, S9, S15, S18, S19, S20, S29, S30, S31, S33, S34, S35, S36, S38, S39, S40, S41, S42, S43, S47, S48, S49, S50, S51, S52, S53, S54, S55, S56, S61, S62, S63, S64, S65, S66, S67, S68, S69, S71, S72

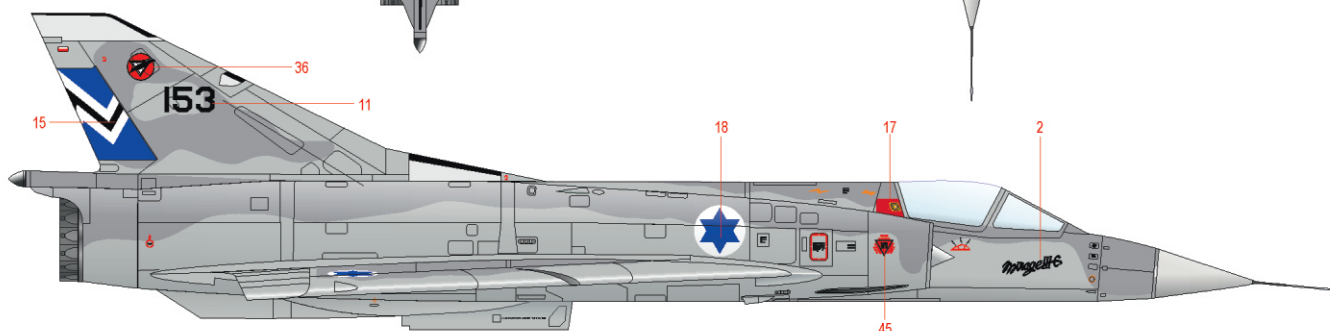
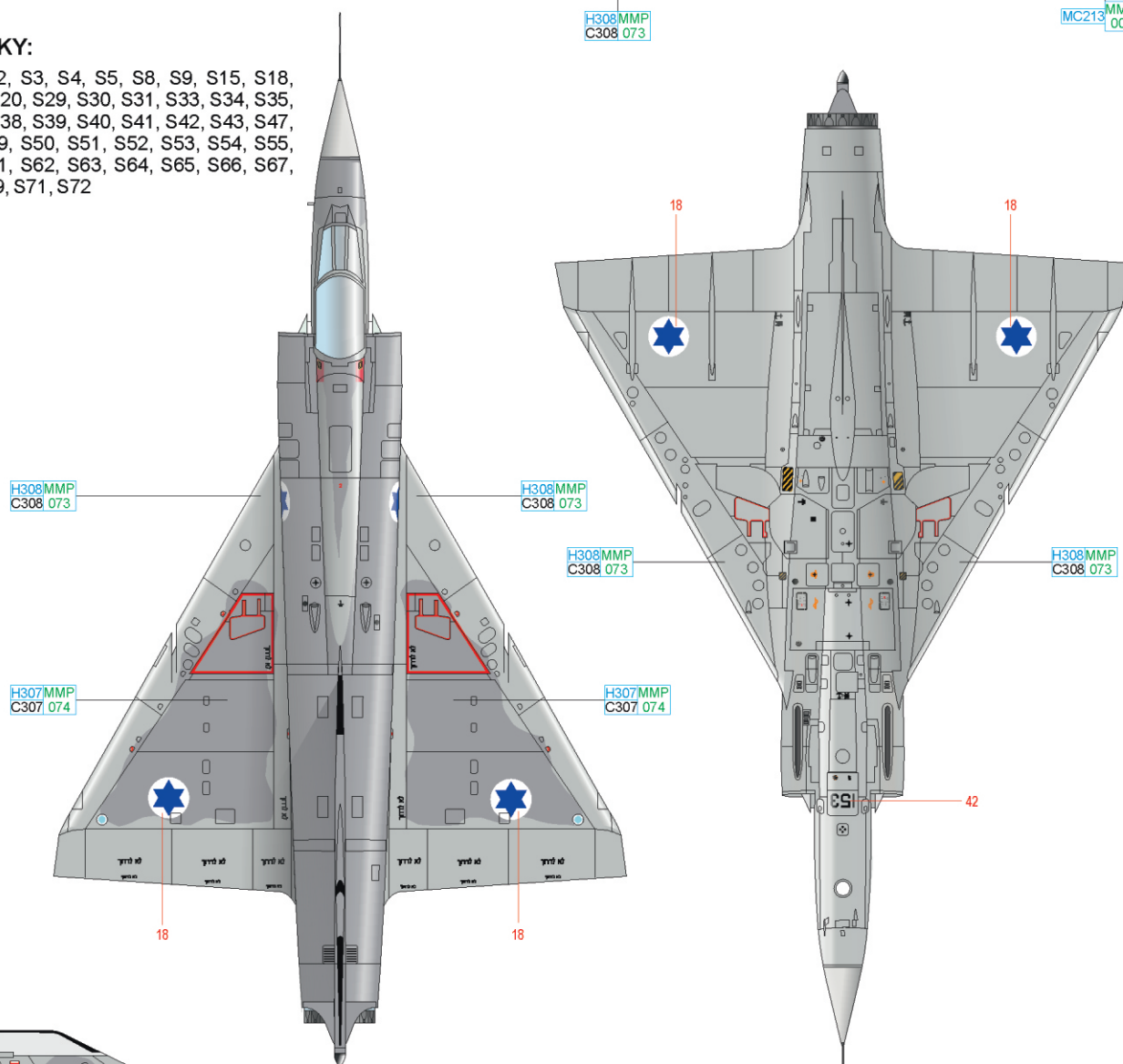

STEEL MC213 MMM 006

GRAY H307MMP C307 074 GRAY H308MMP C308 073 GRAY H311MMP C311 095

E č. 758, 119. tajeset, letecká základna Tel Nof, Izrael, 1969

Šachakem s celkem třinácti sestřely na kontě je stroj č. 58 (známý také jako 758, 458 nebo 158). Zde je v původní kovové podobě z roku 1969 v barvách 119. tajeset ze základny Tel Nof. Zajímavostí je počet tří symbolů sestřelů pod kabinou. Podle dostupných údajů by měly být namalované sestřely buď dva nebo čtyři. Jedná se o tyto sestřely: 8. června 1967, pilot Reuven Rozen (egyptský MiG-21), 21. května 1969, pilot Reuven Rozen (egyptský MiG-21) a 2. července 1969, pilot Ejtan Karmi (dva egyptské MiGy-21). V dalších letech letoun prošel službou i u 101., 253. a 254. tajeset a izraelsí piloti dosáhli v jeho kabině dalších 9 sestřelů. V roce 1982 byl prodán do Argentiny, kde s označením C-714 sloužil až do vyřazení v roce 1990.

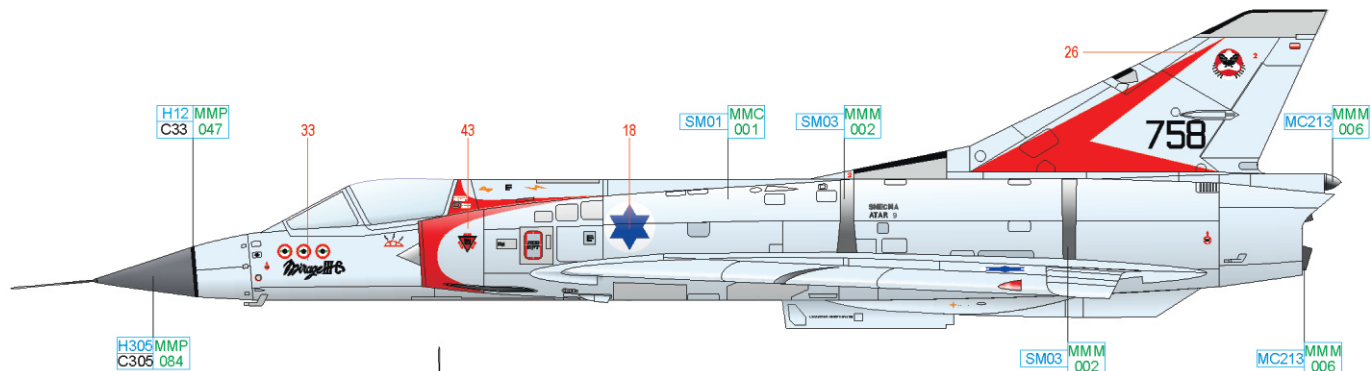

POPISKY:

S1, S2, S4, S5, S6, S7, S10, S11, S12, S13, S14, S15, S16, S17, S18, S23, S24, S25, S26, S27, S28, S29, S30, S31, S32, S33, S34, S35, S36, S38, S39, S42, S43, S46, S47, S49, S50, S51, S52, S53, S54, S55, S56, S57, S58, S59, S61, S62, S63, S64, S65, S66, S67, S68, S70, S71, S72, S73, S75, S76, S78

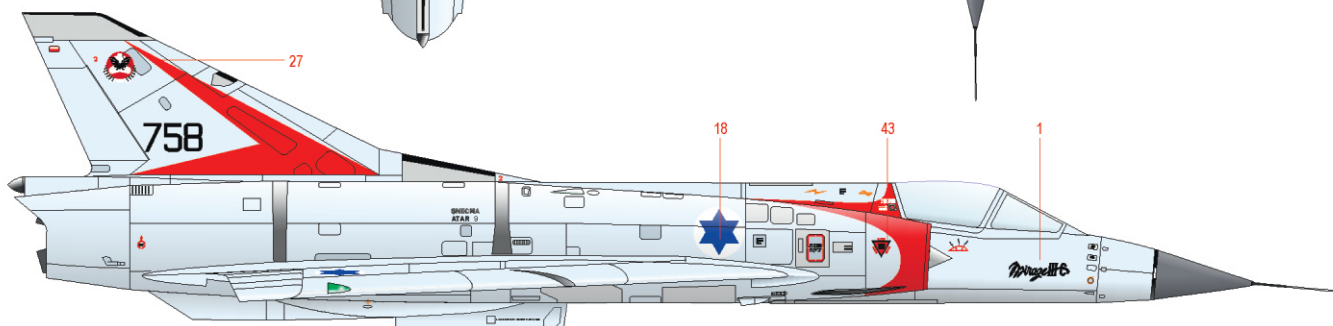
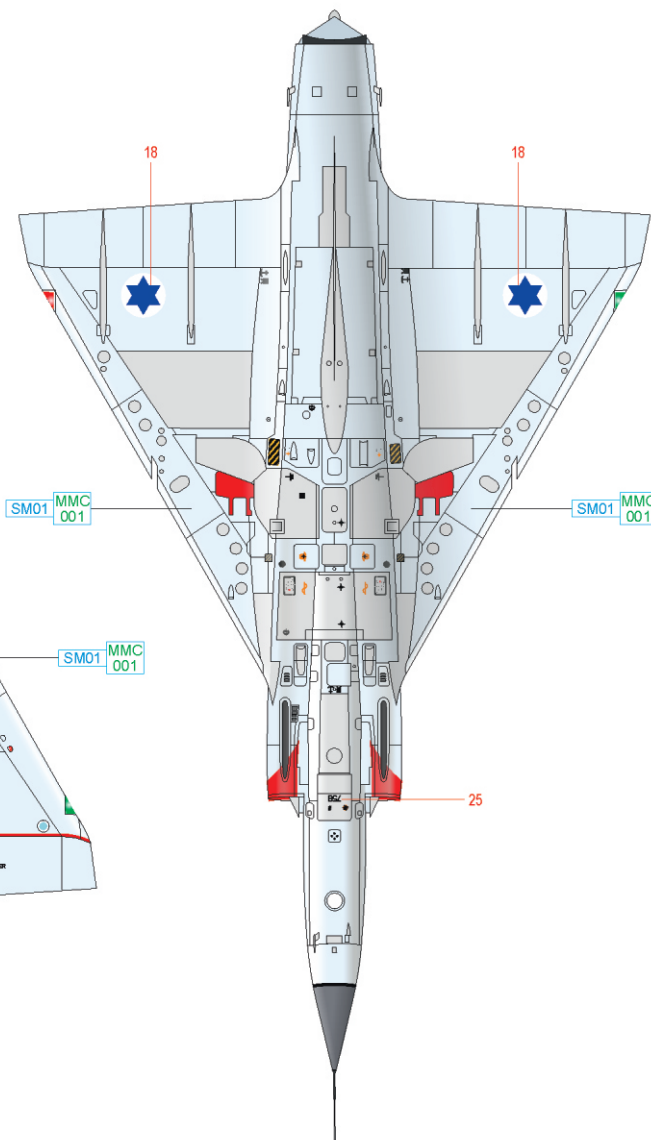
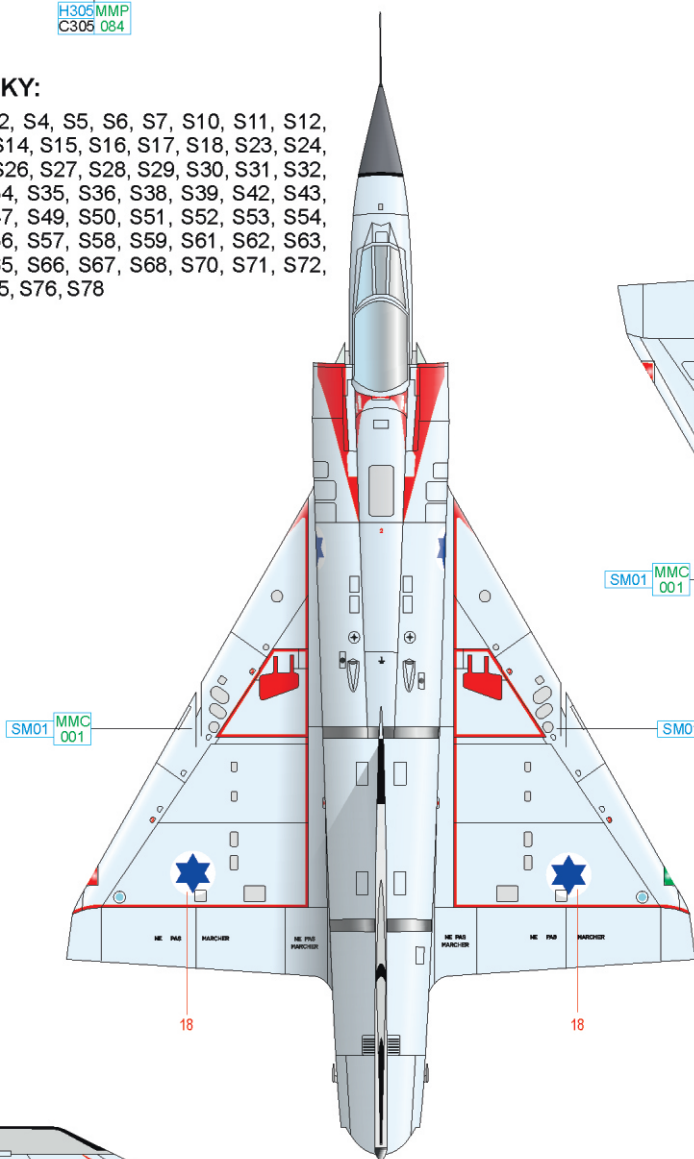

SUPER CHROME SM01 MMC 001 SUPER IRON SM03 MMM 002 STEEL MC213 MMM 006 BLACK H12 MMP C33 047 GRAY H305 MMP C305 084

eduard

